

Sinterit LISA X

SLS 3D PRINTER

Original user manual



Please read the manual before using the product.
For the most up-to-date manual,
visit our website: www.sinterit.com/support/





In order to ensure safe and efficient operation of Sinterit's devices and products, please make sure to follow the instructions and safety guidelines outlined in this manual. Please be sure to keep this document for future reference.

Table of Contents

1. Glossary	4
2. Safety information	4
2.1 Symbols and visual cues	4
2.2 General safety guidelines and personal protection information	6
2.3 Electric devices – power supply and grounding system	7
2.4 Printers – General usage safety guidelines	8
2.5 Printers – Safety during repair and maintenance	9
2.6 Powders – Safety while working with powder	9
2.7 Working with hazardous and potentially hazardous powders	10
2.8 Powders – first aid	11
2.9 In case of fire	11
3. General information	12
3.1 Intended use	12
3.2 Operating requirements	12
3.3 Technical specification	13
3.4 Printer description	15
3.5 Printer safety plate	17
3.6 Radio equipment information	17
4. Unpacking Lisa X	18
5. First start-up	19
5.1 Powering on and starting the printer	19
5.2 Mounting the laser protective glass	21
5.3 Connecting the printer to the Wi-Fi network	22
5.4 Main menu	22
6. Preparing to print	24
6.1 General information	24
6.2 Choosing the file	24
6.3 Filling the print chamber with powder	25
6.4 Preparing the printing chamber	26
6.5 Final steps before printing	27
7. During printing	28
7.1 Printing process	28
7.2 Emergency stop pushbutton (E-STOP)	29
8. Removing and cleaning the printout	30
9. Cleaning the printer	32
9.1 Cleaning the print chamber	32
9.2 Cleaning the overflow container	34
10. Printing with speciality powders	35
11. Powder refreshment	36
11.1 Powder refreshment with PHS	36
11.2 Powder refreshment with Powder Sieve or metal strainer	37
12. Basic maintenance	38
12.1 Basic maintenance	38
12.2 Cleaning the pyrometer window	40
12.3 Cleaning the laser protective glass	40
12.4 Replacing Recoater cord	42
12.5 Replacing Print Bed sealing	45
12.6 Replacing Feed Bed sealing	48
12.7 Cleaning the F-Theta Scanning Lens	51
12.8 Replacing Reflector sealing	53
12.9 Replacing Infrared bulb	55
12.10 Cleaning Recoater Roller	56
12.11 Checking the tension of the Recoater Drive Unit cord (rev. A-B)	58
12.12 Checking the tension of the Recoater Drive Unit cord. (rev. C)	59
12.13 Cleaning the inner rear tray	61
12.14 Spare parts for Lisa X	61



13. Expert Mode	62
13.1 Important safety information	62
13.2 Enabling „Expert Mode”	62
13.3 Multi-users	63
13.4 Deactivation of the expert mode.....	63
13.5 Options to work in expert mode.....	64
13.6 Expert mode – disclaimer	65
13.7 Expert mode – liability limitation	65
14. Industry 4.0	66
15. Technical support	68
16. Packing the machine for shipping	68
16.1 Preparing the printer	68
16.2 Packing the printer into the flight case.....	68
17. General legal information	69
18. Disclaimer	69
19. Trademarks	69
20. Warranty information	70
21. Technical support	70
22. Residual risk	71
23. Centre of gravity of the Lisa X device	72
23.1 Device with closing lid	72
23.2 Device with open lid.....	72
24. EC/EU Declaration of Conformity	73



1. Glossary

The following terms and forms have been adopted and used in the manual.













- **Print Bed** – a chamber where the powder is sintered and where the 3D model is created.
- **Feed Bed** – a chamber that stores new, unsintered powder. From this chamber, the powder is taken layer by layer into the Print Bed.
- **Cake** – contents of the Print Bed after printing is complete. It consists of the printed model and the unbaked powder around the model.
- **IO BOX** – In & Out BOX, a tool designed to pull the cake out of a Print Bed.
- **Flight case** – a special case used to ship the printer.

2. Safety information

2.1 SYMBOLS AND VISUAL CUES

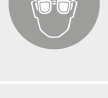







	<p>WARNING! An inevitably dangerous situation which can result in serious injury or even death. Initiation, or omission, of a specific procedure as well as inattention, can cause severe physical injury to the user.</p>
	<p>ATTENTION! Initiation, or omission, of a specific procedure can cause physical damage to the equipment or the user.</p>
	<p>WARNING! Risk of electric shock which can be fatal or cause severe burns. An inevitably dangerous situation, which can result in serious injury or even death, if not mitigated. Before working with any equipment, you should be aware of the dangers associated with the flow of electric current, and become familiar with the standard procedures to prevent accidents.</p>
 	<p>WARNING! Compressed gas! The danger of suffocation! Possibility of unsealing - inert gas has a suffocating effect on people by displacing oxygen from the air. Too low oxygen concentration in the air can lead to unconsciousness and death, if not mitigated. Inhalation exposure may cause short breath, breathing difficulties, headaches and dizziness, with high concentrations of gas disorders of orientation, nausea, fainting, loss of consciousness and eventually death.</p>
	<p>CAUTION! IR laser radiation. Looking directly into the laser beam can cause blindness and skin burns. The laser emits infrared radiation (infrared, IR), which is invisible to humans. Avoid eye or skin exposure to direct or scattered radiation. Do not stare into the beam or view with optical instruments.</p>
	<p>CAUTION! High temperature – do not touch. Excess heat dissipation can cause burns.</p>
	<p>CAUTION! Beware of moving parts which can crush hands.</p>



	CAUTION! Beware of sharp edges which can cause body cuts and injury.
	CAUTION! Beware of intense light.
 	WARNING! Risk of fire and explosion! Avoid fire! Powder dust is flammable.
	ATTENTION! Risk of electric shock. A grounding is used in the printer. Follow the instructions in the User manual and the markings on the printer.
	STOP! Action prohibited.
  	ATTENTION! It is necessary to wear adequate protective clothing, eyewear, face mask, and gloves. Mandatory when working with powder.
	ATTENTION! It is necessary to wear antistatic clothes and shoes. Mandatory action when working with powder.
	IMPORTANT! Information essential to correctly perform a specific task.
	IMPORTANT! You must read the instructions before taking action.
	ATTENTION! Sinterit products and materials may not be suitable for disposal in municipal waste.













2.2 GENERAL SAFETY GUIDELINES AND PERSONAL PROTECTION INFORMATION

	<p>WARNING!</p> <ul style="list-style-type: none">• The Sinterit set of devices, including Sinterit LISA X, is not intended for use in an explosive atmosphere.• The possibility of an explosive atmosphere is anticipated inside the device.• The device is not protected against the risk of explosion from sources other than its own.	
	<p>WARNING!</p> <p>Unless these messages are heeded, operator injuries or printer damage could occur.</p>	
	<p>ATTENTION!</p> <p>If anything during the printer operation concerns you, press the E-STOP button and contact our after sales team: support@sinterit.com</p>	
	<p>WARNING!</p> <p>The following indications are, by themselves, not enough to fully protect against all the hazards that could arise during printer operation. These will have to be integrated with common sense and the experience of the operator, both of which are crucial factors for preventing accidents. Each section of this manual lists further specific safety warnings for the various operations.</p>	
	<p>WARNING!</p> <ul style="list-style-type: none">• Only trained and qualified personnel should install, replace or service the equipment.• The product should be set up in accordance with these instructions and by trained personnel.• Sinterit products may only be safely used or operated by adults and can pose serious risk to children.	
	<p>ATTENTION!</p> <p>When restoring original working conditions, the appointed personnel should always make sure that at the end of the operating procedure, proper printer operation safety conditions are restored, especially the safety devices and the protective guards.</p>	
 	<p>STOP!</p> <ul style="list-style-type: none">• It is forbidden to climb Sinterit's products or equipment, unless and only if they were explicitly designed for that purpose (e.g. stepladders).• Do not lean on the device.	
 	<p>ATTENTION!</p> <p>Wear individual protections. Before starting any work with powder, always wear adequate protective clothing, eyewear, face mask, and gloves.</p>	
	<p>ATTENTION!</p> <p>It is recommended to wear antistatic clothing and shoes. The floor in the working area must be antistatic.</p>	











2.3 ELECTRIC DEVICES – POWER SUPPLY AND GROUNDING SYSTEM

	<p>WARNING!</p> <ul style="list-style-type: none">• Before plugging in the device, make sure the power voltage and frequency are those shown on the machine plate.• When an extension cord is used for the power supply of the product, make sure that the total power consumption of all devices connected to it does not exceed the extension cord's limit. Also, make sure that the total current drawn by connected equipment does not exceed the ampere rating for AC wall outlet.	
	<p>WARNING!</p> <ul style="list-style-type: none">• Use only the power cable supplied with the product.• Do not use power cables from other devices! Using the power cables from other devices or connecting the power cables supplied with the product to other devices may cause fire or electric shock.• The power cable should be placed in such a place that they are not rubbed, cut, pulled or twisted.• Pay special attention to the fact that the power cable is not bent at the points of connection of the printer.• During use, mind the power supply cables and avoid crushing or pulling these.• Periodically check the mains power cable to ensure it is not damaged.• In the event of the cable being replaced, make sure it is protected against water spray and check mechanical strength.• Disconnect the power cable whenever it is planned to shift/transfer the machine.	
	<p>WARNING!</p> <p>In the following situations, unplug the product from the power supply and contact with Sinterit Support:</p> <ul style="list-style-type: none">• the power cable or plug is damaged;• some liquid got into the product;• the product has been dropped or the case has been damaged;• the product does not operate properly or clear changes in efficiency have been observed.	
	<p>STOP!</p> <ul style="list-style-type: none">• Never touch electric wires, switches, buttons, etc. with wet hands.• Never pull the machine by means of the power cable. When connecting/ disconnecting the plug to/from the power socket always hold the cover, not the cable.• In the event of the cable being damaged, the machine must not be used.• Never disassemble, modify or repair the power cable, plug, devices inside the printer, except as described in the product manual.• Do not place objects on the power cable.• Do not place power cable in the way, where it can be a tripping hazard.	
	<p>ATTENTION!</p> <p>It is recommended to use UPS units that, in the case of a momentary power failure, will allow the printing process to finalise.</p>	
	<p>ATTENTION!</p> <p>Industrial equipment, such as provided by Sinterit, must always be connected to a grounded outlet to prevent electric shock in the event of a fault.</p>	









2.4 PRINTERS – GENERAL USAGE SAFETY GUIDELINES



	<p>WARNING! Before printing, always make sure the printer is free of all external materials such as debris, oil, equipment and other objects that could affect the operation and cause injury to people.</p>	
	<p>ATTENTION!</p> <ul style="list-style-type: none">• During printing, if there is a lot of smoke, irritating smell or other alarming circumstances take place, press the E-STOP button. It will immediately cut off the power from the printer.• However, remember that it is impossible to open the printer (e.g.: by lifting the lid) until the temperature inside will not drop below 50°C and the UNLOCK LID option becomes available.	
	<p>WARNING! <u>INERT GAS INSTALLATION</u> Possibility of unsealing - gas has a suffocating effect on people by displacing oxygen from the air. Too low oxygen concentration in the air can lead to unconsciousness and death. Inhalation exposure may cause short breath, breathing difficulties, headaches and dizziness, with high concentrations of gas disorders of orientation, nausea, fainting, loss of consciousness, and death.</p> <ul style="list-style-type: none">• Store in a well-ventilated place.• Do not inhale the gas.• Nitrogen is an inert gas, a natural component of atmospheric air. It is not harmful in the aquatic environment or soil, its adverse effect is limited to the displacement of oxygen.• If you feel any suspicious symptoms, immediately leave the room and go outside/to a well-ventilated room.	 
	<p>ATTENTION! If there is a need to discharge the pneumatic energy accumulated in the printer, the pressure hose supplied to the printer must be disconnected using a quick-release coupling. The pressure will be equalised to the ambient pressure level.</p>	
	<p>ATTENTION! <u>Laser protective glass</u></p> <ul style="list-style-type: none">• The cleaning process of the laser protective glass should be carried out outside of the printer.• Do not clean the laser protective glass under running water.• Only use products with ethyl alcohol. We recommend alcohol pads (available in the Dedicated Powder Tools).	
	<p>ATTENTION! While the printer is working do not touch any other elements besides: the LCD screen, the emergency stop pushbutton (E-STOP), the USB port and the power switch.</p>	



2.5 PRINTERS – SAFETY DURING REPAIR AND MAINTENANCE

	<p>WARNING!</p> <ul style="list-style-type: none">• Only trained personnel should carry out repairs.• Read the user manual carefully before using the printer or doing any maintenance jobs.• During cleaning operations, maintenance jobs or when changing parts, the power switch must be off and the machine must be unplugged by removing the power cable from the socket.• During maintenance jobs, affix a notice to the appliance indicating „MACHINE BEING SERVICED, DO NOT START“.• Do not adjust controls that are not described in the manual.	
	<p>WARNING!</p> <ul style="list-style-type: none">• Structural damage and improper alterations or repairs could change the protection capacity of the printer and therefore void the warranty.• Any alterations to the appliance can only be made by Sinterit Support.• In the event of Customers fitting a tool to the machine not supplied by Sinterit, make sure the safety conditions required by Machine Directive 2006/42/CE are complied with and in any event, Sinterit is unable to accept liability for any problems arising from the use of such a tool.	
	<p>STOP!</p> <p>Avoid using flammable or toxic solvents for cleaning and maintenance such as petrol, benzene, ether and alcohol for cleaning.</p>	 
	<p>ATTENTION!</p> <ul style="list-style-type: none">• Any assembly, installation, adjustment and service work should be carried out with the device free of hazardous substances, including powder and dust in a NOT-CLASSIFIED atmosphere (an area with a non-potentially explosive atmosphere).• It is necessary to check the tightness of the device before each start-up, particularly after service work.	

2.6 POWDERS – SAFETY WHILE WORKING WITH POWDER

	<p>WARNING!</p> <ul style="list-style-type: none">• When working with the polyamide powder or other designated printer powder for the Sinterit Lisa X printer, always wear personal protection dedicated to this device (protective glasses, protective gloves, protective dust mask).• When working with powder, avoid inhalation or swallowing and contact with skin and eyes.	 
---	--	--



	<p>ATTENTION!</p> <ul style="list-style-type: none">• Polyamide powder should be stored in tightly closed containers (e.g Sinterit metal container), in a room at room temperature and low humidity.• The powder should be stored out of reach of children and pets.• If the device is not used for a long time, the powder should be removed from the printer and stored in a sealed package (e.g Sinterit metal container).	
	<p>ATTENTION!</p> <p>When printing the smell of melting material may be emitted in intensities which do not affect the health of users. However, in the case of long-term operation of the printer in a poorly ventilated room, the smell may become unpleasant and irritating. Adequate ventilation is recommended in order to create the best printing conditions.</p>	
	<p>STOP!</p> <p>Do not attempt to burn/melt polyamide powder. The resulting sparks and hot mass can cause severe burns. Keep the powder material away from fire.</p>	
	<p>STOP!</p> <p>Do not dispose of in municipal waste! The used powder material should be stored in sealed containers and disposed of in accordance with local policy of waste plastic material.</p>	

2.7 WORKING WITH HAZARDOUS AND POTENTIALLY HAZARDOUS POWDERS







	<p>ATTENTION!</p> <p>This group of powders includes, in particular, the powders PA11 CF (Carbon Fiber) and PA11 ESD. Before working with these powders, it is necessary to read the characteristic sheet of these powders (SDS).</p>	
	<p>ATTENTION!</p> <ul style="list-style-type: none">• Wear individual protection (Protective dust suit, Protective gloves, Protective Glasses, Protective Dust Mask FFP3/N99/P3/N100).• To prevent dust from being inhaled at all times, always wear a dust mask. When entering a PHS room, pay attention to the solid particles that are released during sieving.• Inhalation of the dust can cause serious lung problems.• Hearing protection is required when working with a PHS device. Staying with the device unprotected for long periods may reduce attention and impair hearing.• The operator must always wear antistatic shoes.	
	<p>ATTENTION!</p> <p>Dust from PA11 Cf and PA11 ESD powders is particularly hazardous to the lungs and it is necessary to limit their ascent into the air.</p>	



2.8 POWDERS – FIRST AID

	<p>ATTENTION!</p> <ol style="list-style-type: none"> 1. POWDER IN THE AIRWAYS <ul style="list-style-type: none"> • The affected should be removed onto fresh air until symptoms subside. • In case of unrelenting symptoms, consult a physician. 2. POWDER ON THE SKIN <ul style="list-style-type: none"> • Wash the substance off with soap. In case of persistent skin irritation, consult a physician. 3. POWDER IN CONTACT WITH THE EYES <ul style="list-style-type: none"> • Thoroughly wash the eyes under running water for at least 5 minutes. • In case of unrelenting symptoms, consult an ophthalmologist. 4. POWDER INGESTED <ul style="list-style-type: none"> • Thoroughly rinse the mouth under running water for at least 5 minutes. Drink additional water, in small sips, in order to dilute stomach contents. DO NOT INDUCE VOMITING! • In case of unrelenting symptoms, consult a physician.
---	---

2.9 IN CASE OF FIRE

	<p>WARNING! DEVICE - EXTINGUISHING FIRE Risk of electrocution when extinguishing fires on electrical equipment!</p> <ul style="list-style-type: none"> • Observe local fire regulations when extinguishing a fire. • If only possible, disconnect the power from the device. • Match the extinguishing medium and the extinguishing equipment to the general conditions on-site. • Sinterit recommends using Dry Chemical Powder (ABE/BE) or Carbon Dioxide extinguishers for electrical extinguishing devices. 	 
	<p>WARNING!</p> <ol style="list-style-type: none"> 1. POWDERS - EXTINGUISHING FIRE All commonly used fire extinguishers are permitted – Carbon dioxide (CO₂), dry extinguishing powder, alcohol-resistant foam, and atomized water. Do not use a high-pressure water jet! 2. COMBUSTION PRODUCTS The range of possible combustion products includes simple asphyxiants (CO₂, nitrogen oxides) and toxic substances (carbon monoxide, cyanide). It is paramount to avoid inhaling the smoke, and in such an event, promptly evacuate onto fresh air and seek immediate medical attention. 	 



3. General information

3.1 INTENDED USE

Sinterit Lisa X is a compact 3D printer, making use of the selective laser sintering (SLS) technology in additive manufacturing (AM) processes. In its operation, it uses powdered polymers as the source material. The device enables professional and quick manufacturing of physical 3D objects from their digital models. Improper use of the machine may be dangerous for the operator and damage the machine. The device is intended for professional use only and must not be placed in the home or office.

3.2 OPERATING REQUIREMENTS

It is strongly recommended that the environment, where the machine will be installed and operated, match the criteria listed below:

Condition	Value / Description
Air humidity	40-59 [%]
Storage conditions	0-40 [°C] (32-104 [°F])
Suggested air conditioning setting while the printer is in use	16-25 [°C] (61-77 [°F])
Optimal ambient temperature while the printer is in use	22 [°C] (72 [°F])
Ventilation	Min. 4 full air changes per hour
Minimum surface area of the working room	3.4 [m ²] / 36.5 [ft ²] with vacuum 5.4 [m ²] / 58.1 [ft ²] without vacuum
Minimum doorway width	0.9 [m] / 2'11.5"
Minimum room height	Min 2.4 [m]
Minimum lighting requirement	500 [lx]

It is additionally advised that a hygrometer (air humidity sensor) be installed in the immediate vicinity of the printer, in order to enable monitoring and control.



IMPORTANT!

The room where the printer is operated needs to be well-ventilated, with stable air temperature and humidity; kept relatively clean, ergonomic and arranged with an efficient workflow in mind.



ATTENTION!

The printer should not be placed directly next to an AC power source or air vents.



3.3 TECHNICAL SPECIFICATION

GENERAL INFORMATION	
Technology	SLS - selective laser sintering
Laser type	IR Fiber Coupled Diode Laser, 30W; $\lambda = 976 \pm 3$ [nm] rated to > 30,000 hrs
Laser scanner type	Galvo
Dimensions	650x610x1200 [mm] (25.6x24.0x47.2 [in])
Weight	145 [kg] (319.7 [lbs])
PRINT VOLUME	
Max size of print diagonally¹	398 [mm] (15.7 [in])
Max print volume	TPU based / Flexible materials: 130x180x340 [mm] (5.1x7.1x13.3 [in]) PA / PP: 130x180x330 [mm] (5.1x6.7x13.3 [in])
PRINTER PARAMETERS	
Size of Print Bed	150 x 200 x 350 [mm] (5.9 x 7.9 x 13.8 [in])
Layer height Z (min-max)	0.075 - 0.175 [mm] (0.003 - 0.006 [in])
Build Speed	up to 14 [mm/h] (0.55 [in/h])
PRINT FEATURES	
Min. wall thickness	from 0.5 [mm] (0.020 [in])
Hole diameter	from 0.5 [mm] (0.020 [in])
Moving part clearance	from 0.2 [mm] (0.008 [in])
ADDITIONAL PRINTER FEATURES	
Inert gas control system	built-in
Average inert gas consumption	0.48 [m ³ /h] = 8 [l/min.]
Coupling installed in Lisa X	Pneumatic quick-coupling Male Plug Nipple DN 7.2
SOFTWARE	
Software²	Sinterit Studio
Supported file types	STL, 3MF, OBJ, 3DS, FBX, DAE
Output file types	*.scode, *.sspf, *.sspzf



OS compatibility	Microsoft Windows 10 or higher
COMMUNICATION	
LCD screen	9" interactive touchscreen
On-board camera	Built-in
Connectivity	WiFi / Ethernet / USB
HEATING SYSTEM	
Independent	4 modifiable zones: print chamber , print surface, cylinder and piston - 16 independent heating elements
Max temperature in the chamber	210 [°C] / 410 [°F]
POWER	
Operating voltage	230 [V] AC, 50/60 [Hz], 8 [A] or 100-120 [V] AC, 50/60 [Hz], 15 [A]
Average power consumption	0.85 [kW]
Maximum power consumption	1.65 [kW]
One phase electrical circuit secured by:	<ul style="list-style-type: none">• fuse rated at B16 [A];• residual current circuit breaker 30 [mA];• correctly working grounding system



3.4 PRINTER DESCRIPTION

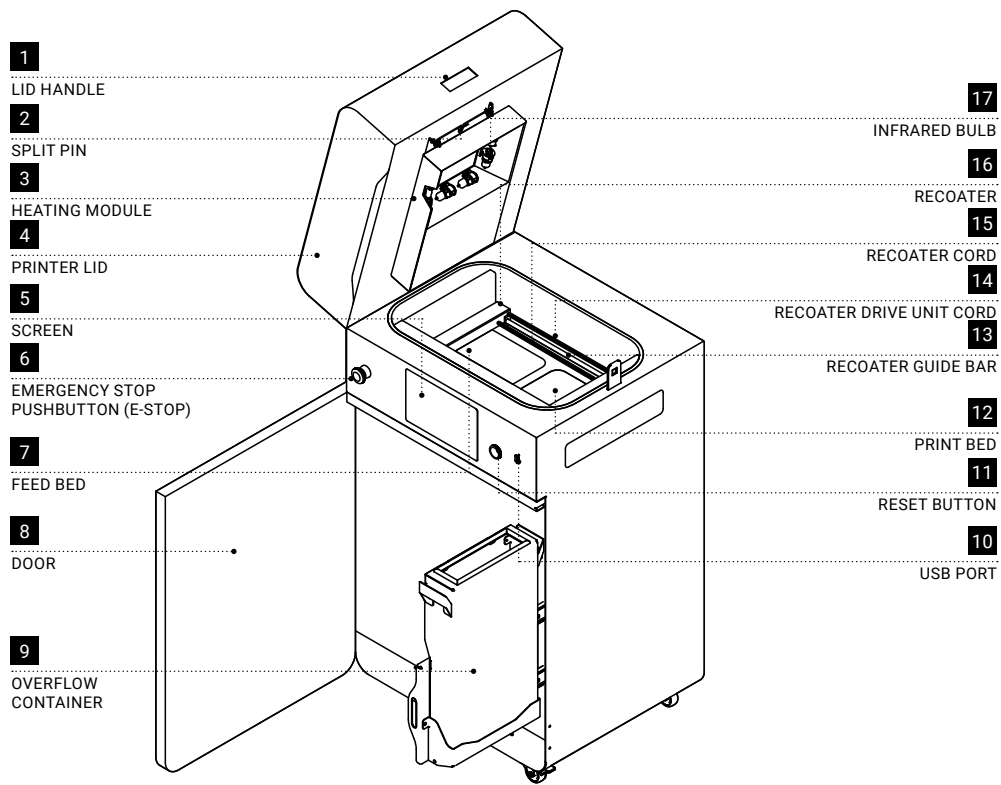

Fig. 3.1 Front view of the printer, heating module and overflow container.

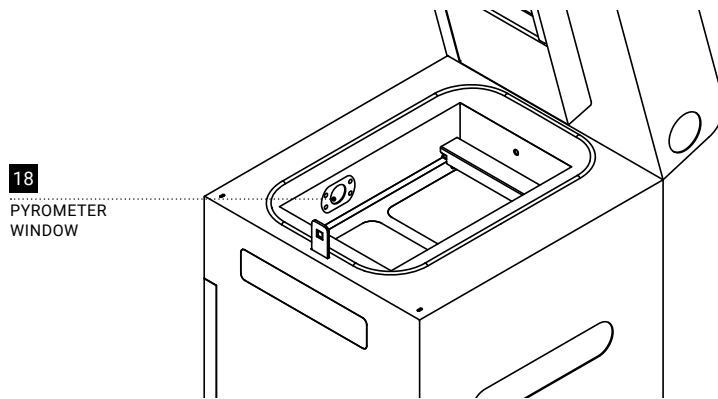

Fig. 3.2 View of the print chamber.

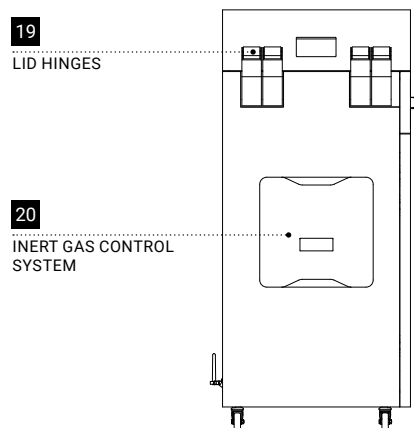

Fig. 3.3 View of the left side of the printer.

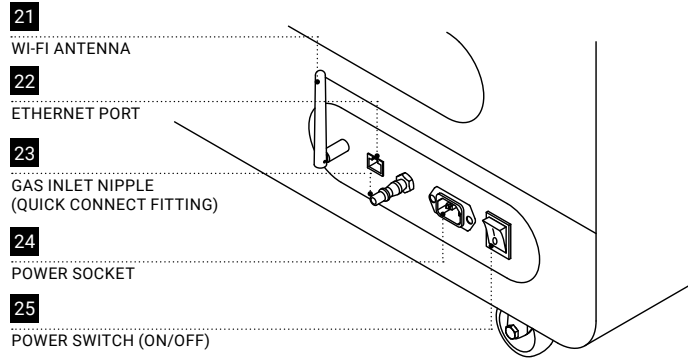

Fig. 3.4 View of the back of the printer.

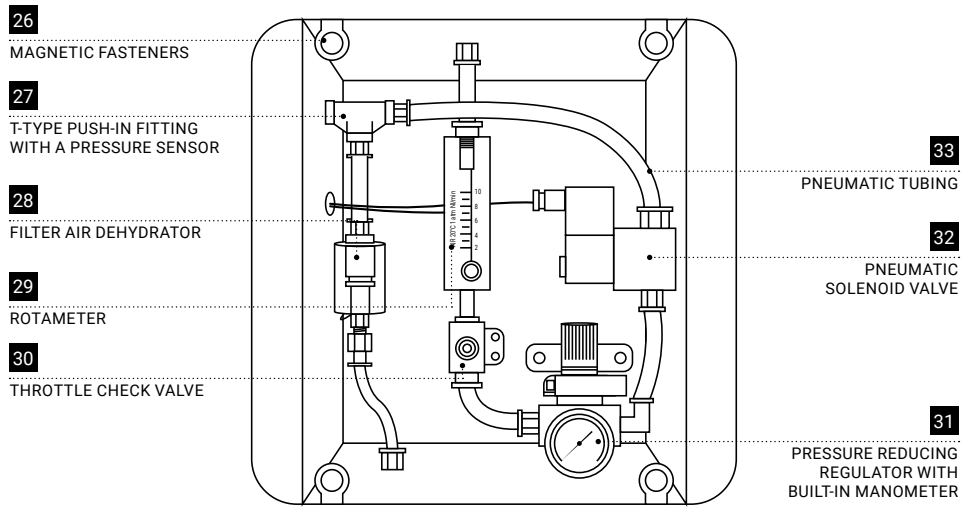







Fig. 3.5 View of the inert gas control system.



3.5 PRINTER SAFETY PLATE

DO NOT REMOVE THIS LABEL!				
Manufacturer  Sinterit sp. z o.o. ul. Nad Drwina 10/B-3, 30-741 Krakow, Poland www.sinterit.com support@sinterit.com		Name Sinterit LISA X Serial number		
IEC Protection Class		Machine type		
 Class 1		SELECTIVE LASER SINTERING 3D PRINTER		
IP Code		AC current		
IP20		8 [A] / 230 [V] AC		
   		Short-circuit current rating	6 [kA]	
		Contains devices FCC	FCC ID: 2ABCB-RPICM4	
		Laser product class	CLASS 1 IR LASER PRODUCT INVISIBLE LASER RADIATION	
		Embedded laser product class	CLASS 4 IR LASER PRODUCT INVISIBLE LASER RADIATION	
			wavelength	$\lambda = 976 \pm 3$ [nm]
			beam divergence	$\theta = 13^\circ$
			beam output	CW (CONTINUOUS WAVE)
		maximum power	30 [W]	
WARNING! Read and understand operator's manual and all other safety instructions before using this machine. Failure to follow operating instructions could result in serious injury. Complies with 21 CFR 1040.10 and 1040.11 except for conformance with IEC 60825-1 Ed.3., as described in Laser Notice No. 56, dated May 8, 2019.				

3.6 RADIO EQUIPMENT INFORMATION

Sinterit Sp. z o. o. hereby declares that the radio device used in the Lisa X printer complies with the RED Directive 2014/53/EU.





The full text of the EU Declaration of Conformity is available at the end of this manual.

The device has a built-in WiFi network card (IEEE 802.11b/g/n/ac 2.4/5 GHz), model RPICM4.

Frequency bands supported	Output power
2400 - 2483 [MHz]	<20,0 [dBm]
5150 - 5850 [MHz]	<23,0 [dBm]



4. Unpacking Lisa X

	WARNING! The device weighs approx. 150 [kg]. Two adults will be needed to unpack the Lisa X printer properly and safely.	
	IMPORTANT During installation, watch out for metal edges and glass parts of the device and flight case. Wear protective gloves.	
	IMPORTANT! Please make sure that the printer was not damaged during shipping. In case of any issues or questions, please contact technical support: support@sinterit.com .	
	WARNING! When driving the printer down/up the gangway, check carefully that the wheels are in the guides.	

You will need: protective gloves, two people, utility knife

1. Cut through the protective foil covering the flight case.
2. Unlock the locks on the flight case door (4 pcs.). Lift the lock handle up to a perpendicular position, then turn it clockwise.
3. Take the flight case cover off.
4. Lift the gangway support and lower the gangway.
5. The power cable is under the printer. Take it out.
6. Unlock the wheels (there are 2 locks).
7. Slide the printer out of the flight case. Guides were installed on the gangway for a comfortable and safe descent. This step requires the help of another person.
8. Place the printer in its desired location, then lock the wheels.

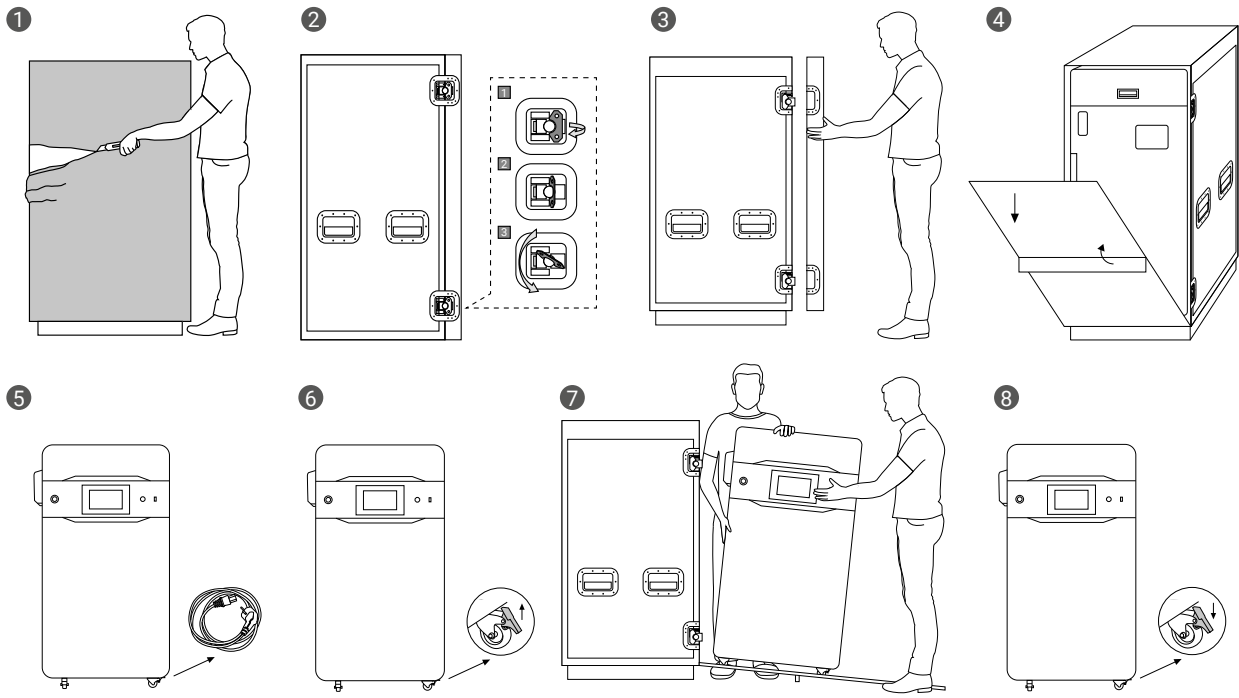

5. First start-up

	<p>IMPORTANT! When the printer is turned on for the first time, a short introduction will be shown on the screen, allowing you to familiarise yourself with the machine's operation.</p>
	<p>IMPORTANT! The accessories in the Dedicated Powder Tools recommended when working with the printer are not part of the printer you purchased. For more information, visit our website: www.sinterit.com.</p>

5.1 POWERING ON AND STARTING THE PRINTER

1. Connect the printer to power (fig. 5.1).

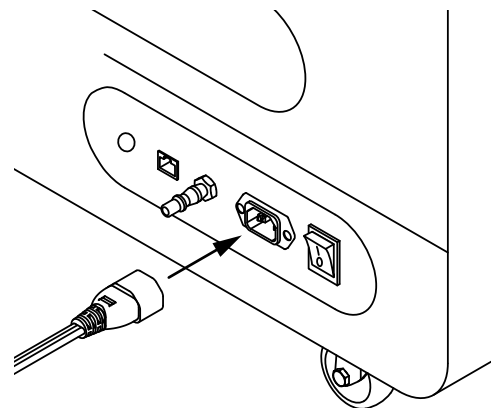

Fig. 5.1 Connecting the power cable to the power socket.

	<p>ATTENTION! Lisa X is supplied with 230 [V]. If you wish to connect the machine to 110 [V], use the voltage converter included with the printer.</p>
--	---



2. Flip the power button on the back of the printer to the **I** position.
3. Make sure that the E-STOP button is released. If not, twist it clockwise up to the stop and release (fig. 5.2).

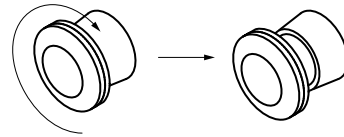

Fig. 5.2 Releasing E-STOP button.

4. After a few seconds, a short tutorial will appear on the screen. The following steps will be explained in detail later in the tutorial.
5. Adjust the position of the screen to yourself. Pull the strap and change the orientation of the screen.
6. Connect the source of inert gas to the inlet nipple on the back of the printer. After connecting, toggle the button on the screen. This step is optional.
7. Choose **UNLOCK LID** on the printer screen.
8. Push on the lid and pull it up using the lid handle (fig. 5.3).



IMPORTANT!

After 10 seconds the electrolock will reactivate and it will no longer be possible to lift the lid. If you still want to open the printer, slide the **UNLOCK LID** button again on the printer screen.

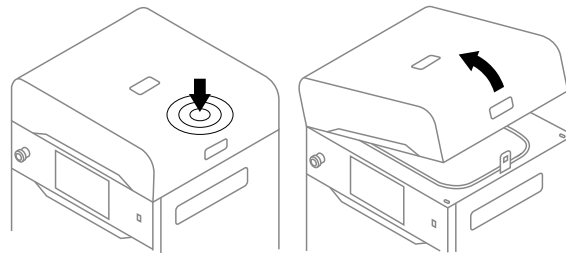

Fig. 5.3 Lifting the printer lid.

9. Remove the Start up box with the laser protective glass and other accessories (fig. 5.4).

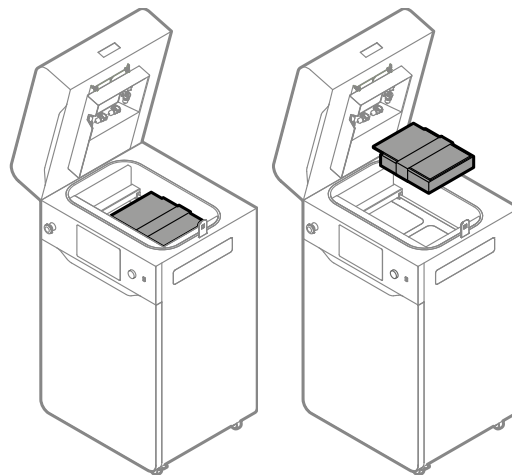

Fig. 5.4 Removing the box with accessories.



5.2 MOUNTING THE LASER PROTECTIVE GLASS



ATTENTION!

Beware of sharp edges. Wear the protective gloves, in order to prevent cutting yourself on the sharp edge of the laser module.

1. Remove the split pin from the heating module.
2. Lower the heating module.
3. Take the laser protective glass out of the box. Then put the box in the flight case for safekeeping.
4. Delicately wipe the glass on both sides with a cotton cloth soaked in 2% salicylic spirit (ethanol solution) or another ethanol-based cleaning solution. You may also use cleaning wipes provided in Dedicated Powder Tools.



IMPORTANT!

Do not use isopropyl alcohol to clean the laser protective glass.

5. Wipe the glass again on both sides with a dry cotton cloth.
6. Slide the metal tabs of the laser protective glass into the mounting brackets below the laser module.
7. Lock the laser protective glass in place by mounting and tightening the two quick release nuts.
8. Lift the heating module.
9. Reinsert the heating module safety pin.

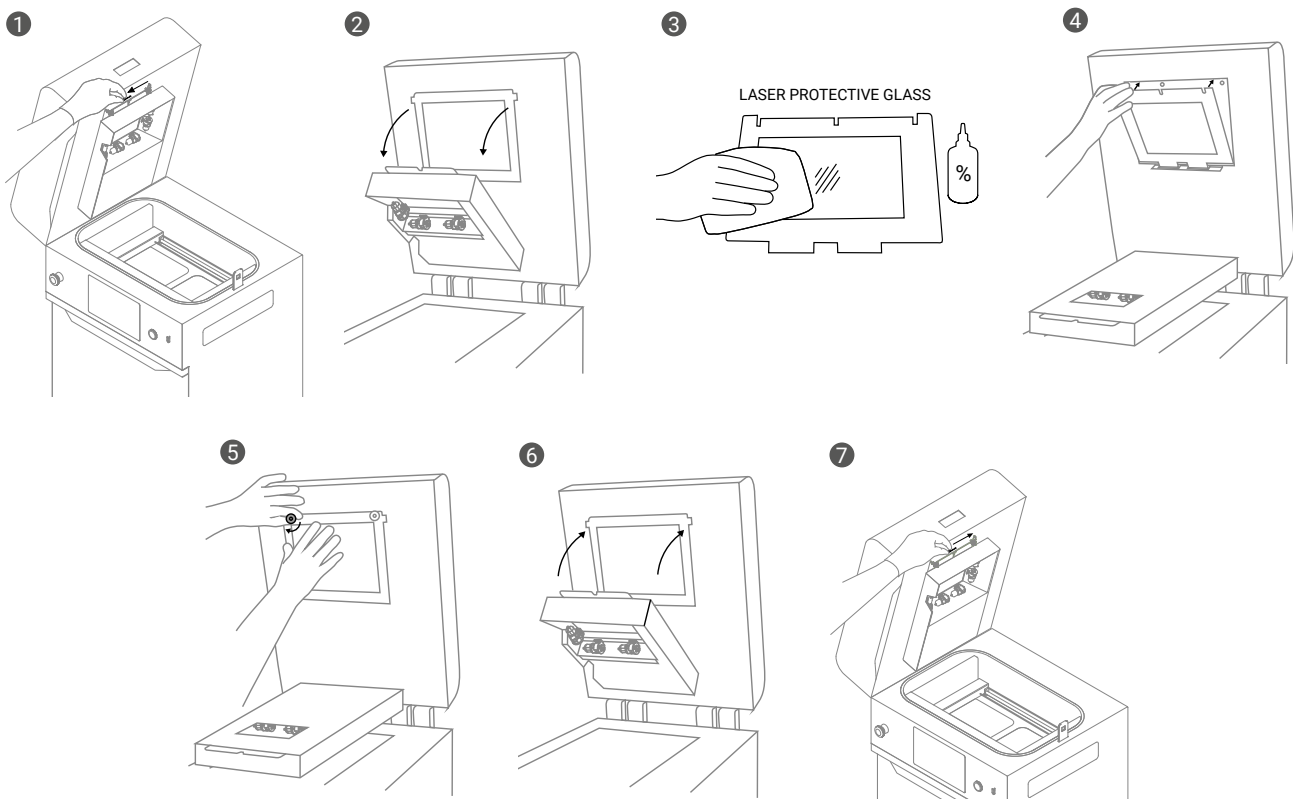

Fig. 5.5 Mounting the laser protective glass.



5.3 CONNECTING THE PRINTER TO THE WI-FI NETWORK

1. Remove the antenna from the Start up box.
2. Insert antenna connector and rotate clockwise to lock it in place. Then rotate the antenna on the hinge so that it is facing up. Press **DONE**.

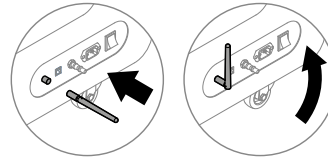

Fig. 5.6 Connecting the antenna to the printer.

FIRST USE	REGULAR USE
<ol style="list-style-type: none"> 3. Press the CONNECT button to select a network. 4. Choose the name of the network, to which you want to connect. 5. Press CONNECT by the chosen network name. 6. Input the password and press ✓. 7. The connection has succeeded, the network will be marked with a ✓. 	<ol style="list-style-type: none"> 3. From the main menu choose SETTINGS ⚙️, or press 📶 top left corner. 4. Choose WI-FI on the printer screen. 5. Choose the name of the network, to which you want to connect. 6. Press CONNECT by the chosen network name. 7. Input the password and press ✓. 8. Once the connection has succeeded, the network will be marked with a ✓.



IMPORTANT!

In case you want to change the connected network, press **FORGET** and repeat the steps above.

5.4 MAIN MENU

The main menu consists of four positions: **PRINTING**, **MAINTENANCE**, **SETTINGS** and **CAMERA VIEW**.

PRINTING – starts a new printing process

- **ADD NEW PRINT JOB** – with this you can start a new print job and start printing process.

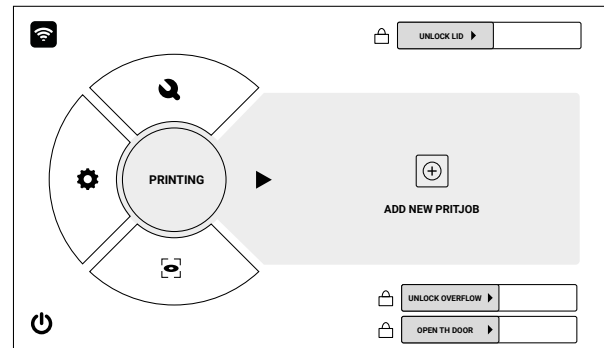

Fig. 5.7 The **START NEW PRINT** screen.

MAINTENANCE – here you can check component service life and perform Lisa X maintenance

- **CLEAN THE PRINTER** – choose this option if you want to clean the printer, e.g. if this step had been skipped after the printout was removed,
- **REMOVE PRINTOUT** – choose this option to remove a printout still in the printer,
- **PRINTER STATUS** – choose this option to check the status of printer components (e.g., how much time is left to change the Recoater short cord),
- **PRINT JOB HISTORY** – choose this option lets you view the history of completed print jobs,
- **CONTROL PANEL** – this option lets you change the position of the overflow, Print and Feed Beds and to initiate homing.

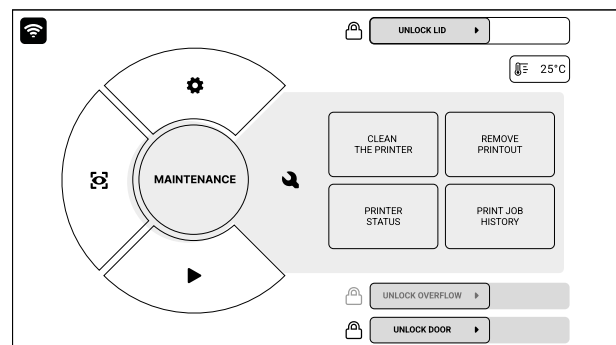

Fig. 5.8 The **MAINTENANCE** screen.



SETTINGS – printer settings

- **CONNECT WITH SINTERIT STUDIO** choose this option to connect with the dedicated printer software on a computer,
- **NETWORK** – choose this option to connect to a Wi-Fi network,
- **SYSTEM INFO** – this option lets you view basic technical information of the printer: current software version, IP address on the network and the last used printing material
- **MORE OPTIONS** – choose this option in order to update the printer firmware or to restore factory settings.

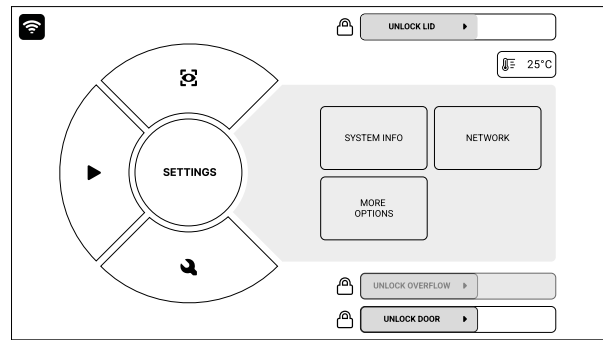

Fig. 5.9 The **SETTINGS** screen.

CAMERA VIEW – view from the built-in camera

- Choose this option to view the inside of the print chamber, including while printing, as seen by the built-in camera.

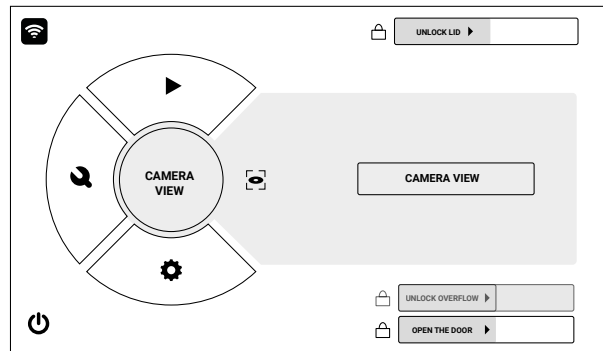

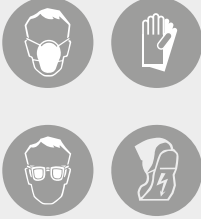

Fig. 5.10 The **CAMERA VIEW** screen.



6. Preparing to print

6.1 GENERAL INFORMATION

	<p>ATTENTION! While preparing the printer for use, it is necessary to read and acknowledge any messages on the screen. Disregarding or skipping any crucial steps of the process can negatively impact the quality of printouts or damage the printer.</p>
	<p>IMPORTANT! While preparing the printer for use, make sure that the overflow container has been emptied.</p>
	<p>ATTENTION!</p> <ul style="list-style-type: none">• Before starting any work with powder, always wear adequate protective clothing, eyewear, face mask, and gloves.• A suitable set is included in the Dedicated Powder Tools for Lisa X.

6.2 CHOOSING THE FILE

	<p>IMPORTANT! In order to print, you will need a file prepared in Sinterit Studio, which you can download from our website www.sinterit.com/software.</p>
---	---

8. Select **PRINTING** from the main menu and press **ADD NEW PRINT JOB**.
9. Choose the new file (**USB**) or recently used file (**RECENT**) (fig. 6.1).
10. The following screen displays some basic information about the processed file (**PRINT JOB**) as well as the current status of the printer (**PRINTER STATUS**). Press next to the component timer for more information. If at this point you want to choose another file to print, press **CHANGE PRINT JOB**.
11. Press **DONE** (fig. 6.2).

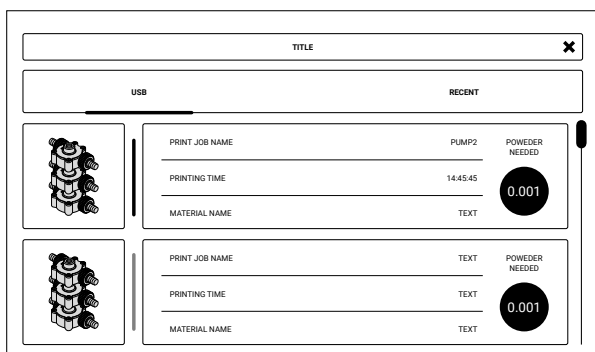

Fig. 6.1 Loading the file.

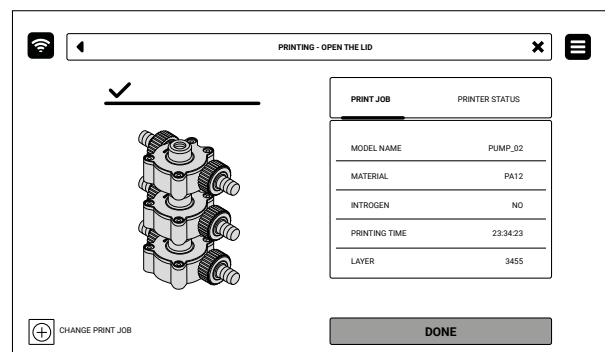

Fig. 6.2. **PRINT JOB** and **PRINTER STATUS** screen.



IMPORTANT!

If any part of the printer requires maintenance or replacement, a corresponding message will appear on the screen.



IMPORTANT!

It is always possible to go back to the main menu on the screen without interrupting the printing process.

6.3 FILLING THE PRINT CHAMBER WITH POWDER

1. Slide the **UNLOCK LID** button to release the electrolock and allow the print chamber to be opened (fig. 6.3).

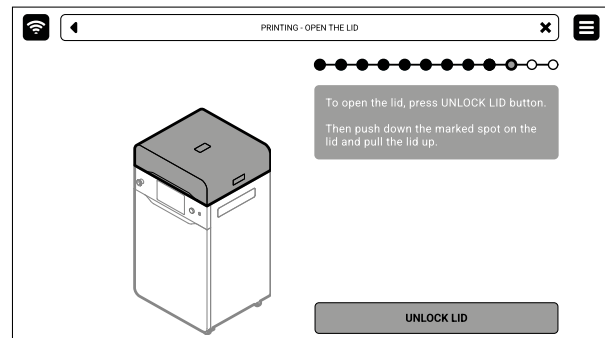

Fig. 6.3 Releasing the electrolock.



IMPORTANT!

After 10 seconds the electrolock will activate and it will no longer be possible to lift the lid. If you still want to open the printer, press the **UNLOCK LID** button again on the printer screen.

2. Push on the lid and pull it up using the lid handle (fig. 6.4).

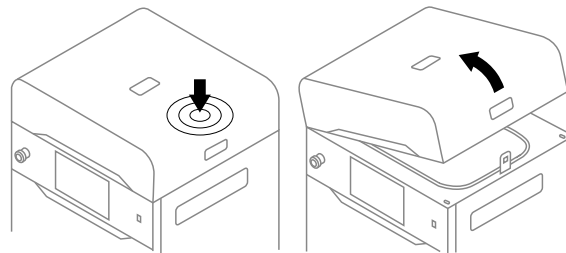

Fig. 6.4 Lifting the printer lid.

3. Make sure the print chamber is free of any unwanted items that may interfere with moving the Recoater.
4. Press **POSITION BEDS** to begin the positioning process of the Beds (fig. 6.5).
5. Once the positioning process is finished, fill the Feed Bed up with the desired powder. You may use the powder funnel provided in the Dedicated Powder Tools (fig. 6.6). Press **DONE**.

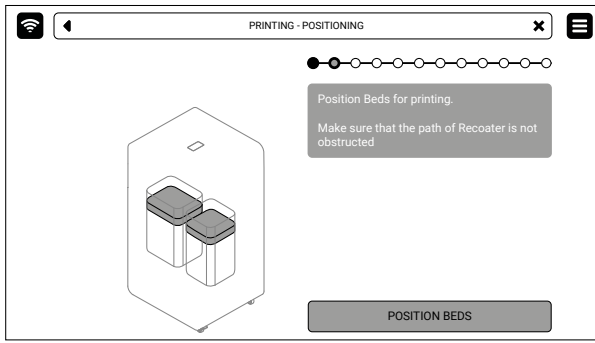

Fig. 6.5 POSITIONING BED screen.

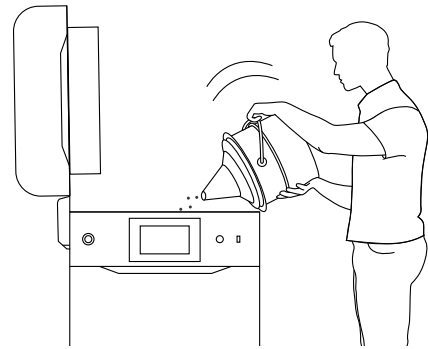

Fig. 6.6 Filling the print chamber with powder using a funnel.

	IMPORTANT! Add a little more powder than fits in the Feed Bed.
	IMPORTANT! The information which powder to use has been displayed on the printer screen as well as in the Sinterit Studio software end report.

6. Compress the powder using the powder trowel provided in the Dedicated Powder Tools. This will release any residual air accumulated in the Feed Bed. Press **DONE**.

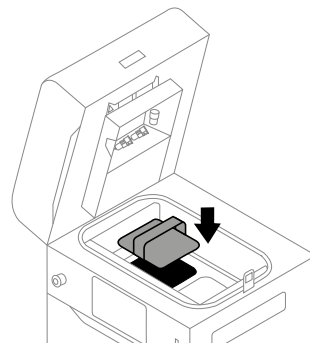

Fig. 6.7. Compressing the powder using the powder trowel.

6.4 PREPARING THE PRINTING CHAMBER

1. Remove powder remaining under the guide bars. You may use the brushes and spatulas provided in the Dedicated Powder Tools. Press **DONE**.
2. Press **START LEVELING** to begin leveling the powder surface (fig. 6.8).

	IMPORTANT! During the powder leveling process you can scrape the excess powder from under the guides with a plastic spatula, for example from the Dedicated Powder Tools set.
	ATTENTION! Risk of crushing hands! The moving Recoater can cause hand injuries.

3. Press **STOP LEVELING** if the surface of the powder in the print chamber is smooth or wait until the Recoater completes the process by itself. You can repeat the process by pressing **REPEAT LEVELING**. Press **DONE** (fig. 6.9).

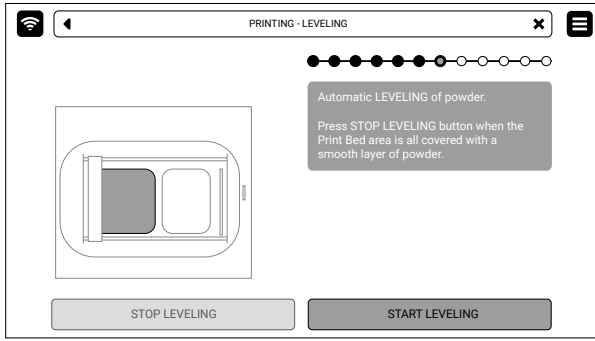

Fig. 6.8 Start **AUTOMATIC LEVELING** screen.

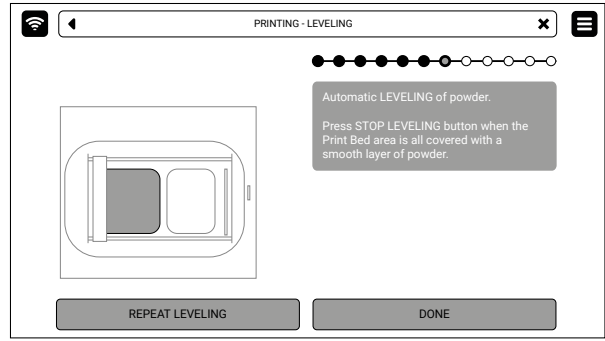

Fig. 6.9 Repeat the Leveling process or move on.

4. Remove powder from the guide bars. Use a brush or a cotton cloth. Press **DONE** (fig. 6.10).
5. Delicately wipe the pyrometer window with a wipe soaked in 2% salicylic spirits (ethanol solution) or another ethanol - based cleaning solution. You may also use cleaning wipes provided in Dedicated Powder Tools.
6. Wipe the pyrometer window again with a dry cotton cloth, in order to remove any alcohol residue. Press **DONE** (fig. 6.11)

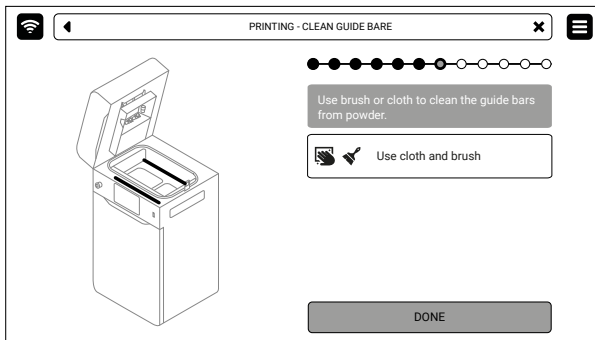

Fig. 6.10 Clean the Recoater guide bars.

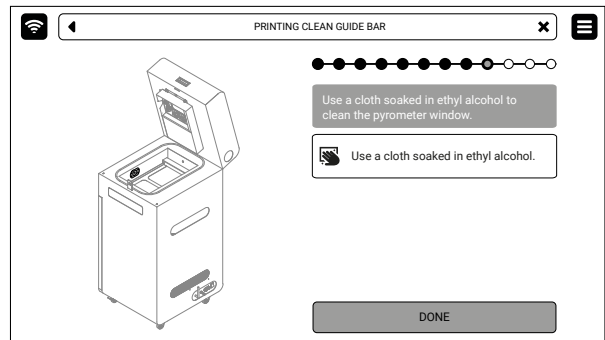

Fig. 6.11 Wipe the pyrometer window.

8. Make sure no miscellaneous items (i.e. spatulas) remain in the print chamber, then close the lid. Press **DONE**.



ATTENTION!

Be careful not to crush your hands when closing the printer lid.



IMPORTANT!

- If the printout requires it, connect the source of inert gas to the inlet nipple.
- Press the **CHECK PRESSURE** button to verify the inert gas control system.
- If the inert gas control system is incorrectly connected, a proper message will appear.

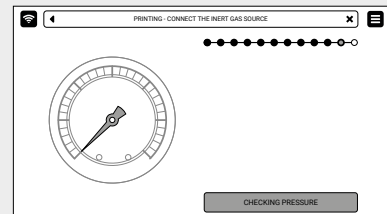

6.5 FINAL STEPS BEFORE PRINTING

1. Press the **RESET** button on the printer, in order to activate the security system.
2. Press **START PRINT** (fig. 6.12). Before printing, an automatic component check will be performed (fig. 6.13)
3. You can stop the process at any time, just press **ABORT PRINTING**.

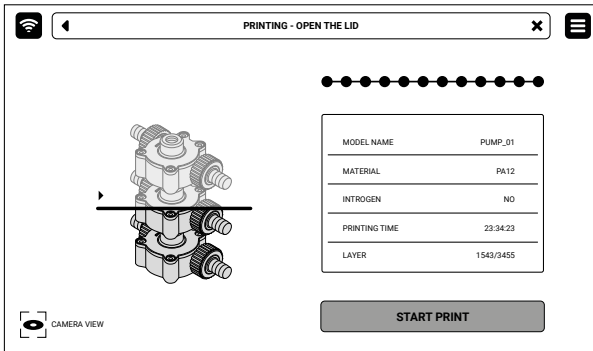

Fig. 6.12 **START PRINT** screen.

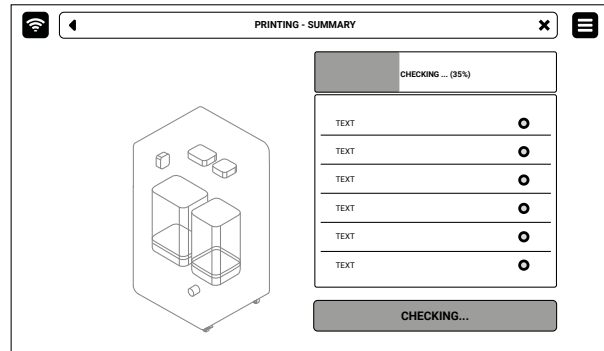

Fig. 6.13 **SELF-CHECK** screen before printing.



ATTENTION!

If anything during the printer operation concerns you, press the E-STOP button and contact our after sales team: support@sinterit.com

7. During printing

7.1 PRINTING PROCESS

1. While the printing is in progress, the display will show basic information about the printing process (fig. 7.1).
2. Choose **CAMERA VIEW**  to see into the print chamber via the built-in camera.
3. In case you want to abort the process, choose **ABORT PRINTING**.

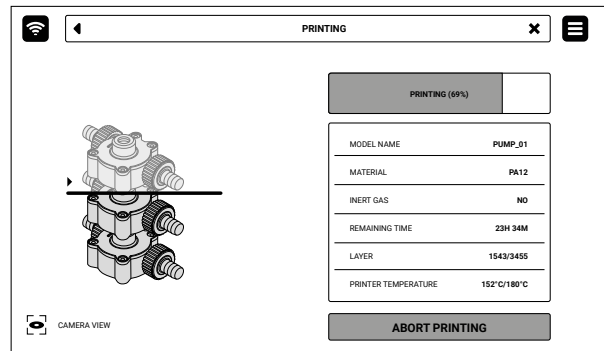

Fig. 7.1 The **PRINTING** screen.



ATTENTION!

While the printing is in progress, in case you observe smoke, an irritating smell or any other dangerous signs, it is important to quickly press the Emergency stop pushbutton (**E-STOP**). This will immediately cut off power to the printer.



ATTENTION!

It is important to note that the printer will not open while the temperature inside the print chamber stays above 50 [°C].



WARNING!

While the printing is in progress, the printer's case might get dangerously hot. Do not touch any elements beside the screen, the E-STOP button, the RESET button, the USB port and the power switch on the back.



7.2 EMERGENCY STOP PUSHBUTTON (E-STOP)

The **E-STOP** button is used for emergency stopping of the printer (Laser system and Beds operation), especially during printing.

If the button is on (pressed), a message and the corresponding image will appear on the screen (fig. 7.1).

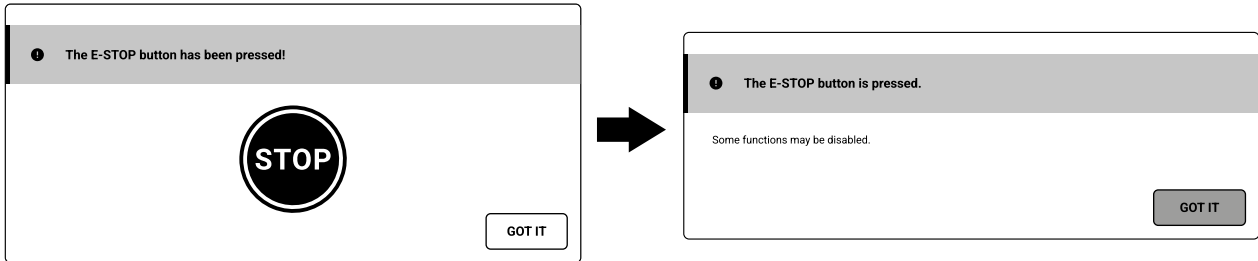

Fig. 7.1 Messages on the screen when the E-STOP button is pressed.

To unlock the **E-STOP** button turn the black collar clockwise until the button springs back to its initial position.

1. **E-STOP button on + Printer inside < 50°C** (during self-check or the start of the printing process) – unlock **E-STOP** button. Opening the printer is possible (after releasing the electrolocks in the lid or door).
2. **E-STOP button on + Printer inside is $\geq 50^\circ\text{C}$** (while printing or cooling) – **PRINT ABORTED** message will be displayed on the screen. Unlock the **E-STOP** button. The opening is not possible until the temperature inside drops below 50°C . Wait, and then press the **REMOVE PRINTOUT** or **UNLOCK LID** button (fig. 7.2).

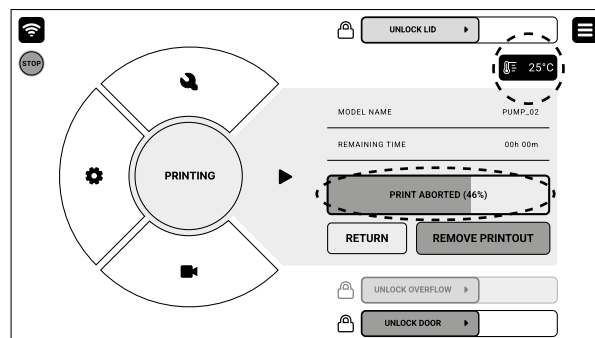

Fig. 7.2 Screen during printing with the E-STOP button pressed.



8. Removing and cleaning the printout

1. Once the screen displays a message saying **FINISHED** (fig. 8.1) the printing process is over. Choose the **REMOVE PRINTOUT** button to retrieve it from the print chamber.
2. After the print is finished, the screen may show a message saying **MAINTENANCE TIME**. It contains information on required maintenance to certain components of the printer in the near future. For more information, see Chapter 12. Basic maintenance. If the message hasn't appeared, it means that no components require any maintenance. Press **GOT IT**.

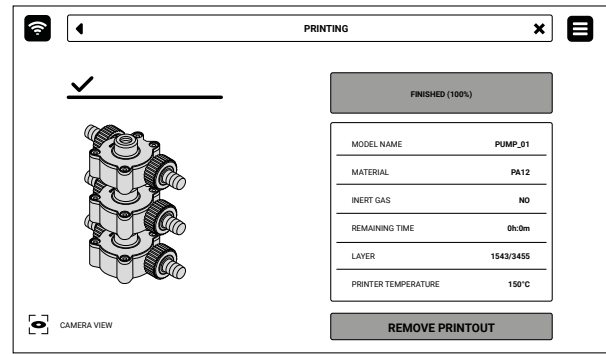

Fig. 8.1 The screen informs the user that the printing is finished.



ATTENTION!

Remember to regularly perform printer maintenance as instructed. Exceeding the designed lifetime of printer components may negatively impact printouts quality and cause damage to the device.

3. Press **UNLOCK LID** on the screen to release the electrolock and allow the printer to be opened. Remember, you only have 10 seconds to open it before the lock activates again.
4. Push on the lid and pull it up using the handle (fig. 8.2).

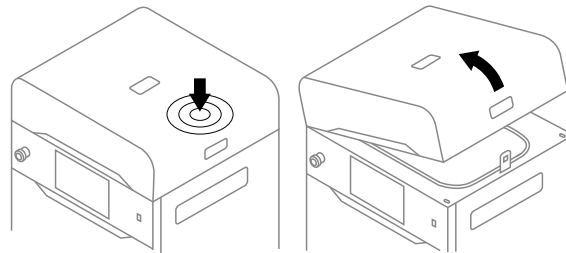

Fig. 8.2 Lifting the printer lid.

5. Make sure no miscellaneous items remain in the print chamber and press **POSITION BEDS**.
6. Place the folded IO BOX inside the print chamber. Make sure its elements are arranged like in the picture (fig. 8.3.)

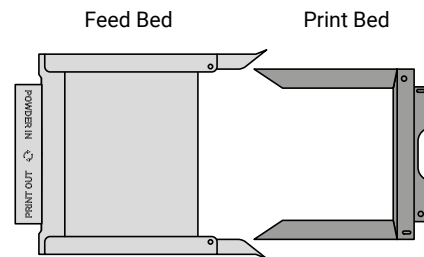

Fig. 8.3. The proper arrangement of the IO BOX, allowing the user to remove the finished printout.



ATTENTION!

While placing the IO BOX in the chamber, make sure you do not accidentally damage its components.



7. Unfold the IO BOX elements as much as possible. Inside the IO BOX you should see a covered Feed Bed and an uncovered Print Bed.
8. Press **REMOVE PRINTOUT** on the screen and wait until the content of the Print Bed (the cake) is ejected.
9. Close the IO BOX (fig. 8.4).

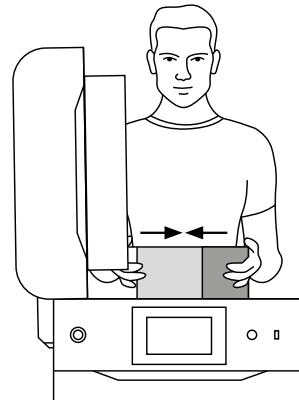

Fig. 8.4 Closing the IO BOX.

10. Carry the IO BOX and its contents onto the foldable tray **1** or on the PHS worktop **2** (fig. 8.5) then press **DONE** on the screen.
11. Clean the printout of unsintered powder. You may use the accessories provided in Dedicated Powder Tools.

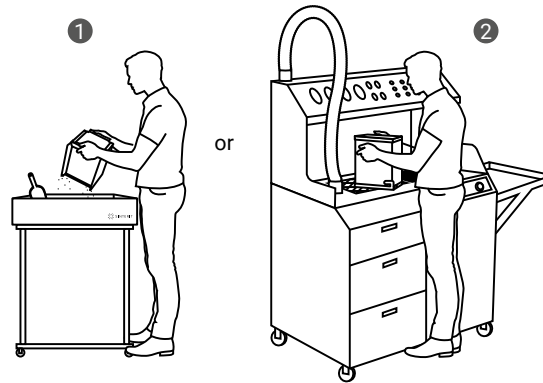

Fig. 8.5. Moving the IO BOX to the Foldable Tray **1** or to the PHS worktop **2** to clean the printout.



9. Cleaning the printer

	<p>IMPORTANT!</p> <p>The SLS powders are hygroscopic (draw moisture out from the air). The print chamber and the overflow container are not 100% airtight. Leaving the powder inside of the printer may cause it to become wet and lose its intended properties.</p>
	<p>IMPORTANT!</p> <ul style="list-style-type: none">• Cleaning the printer is recommended immediately after each printing.• If you do not want to clean the printer immediately after pulling the printout, you can do this later. On the main menu screen, press MAINTENANCE button and then CLEAN THE PRINTER button.

9.1 CLEANING THE PRINT CHAMBER

1. Press **CLEAN THE PRINTER** to start cleaning the printer.
2. Make sure no tools remain in the print chamber. Press **POSITION BEDS** to begin the positioning process of the Beds.

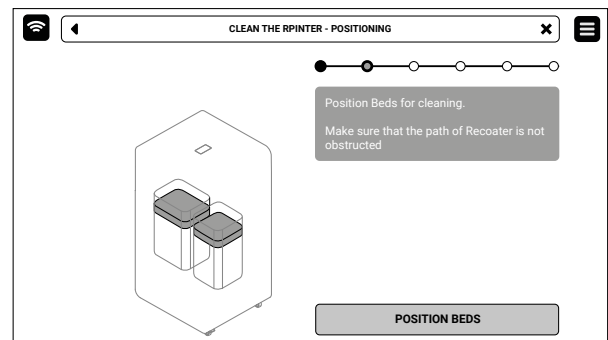

Fig 9.1 Check the inside of the print chamber and click on the **POSITION BEDS** button.

3. For cleaning the printer Sinterit recommends dedicated solutions: the PHS (Powder Handling Station) or ATEX/INTERTEK Vacuum Cleaner with Separator (fig. 9.2).

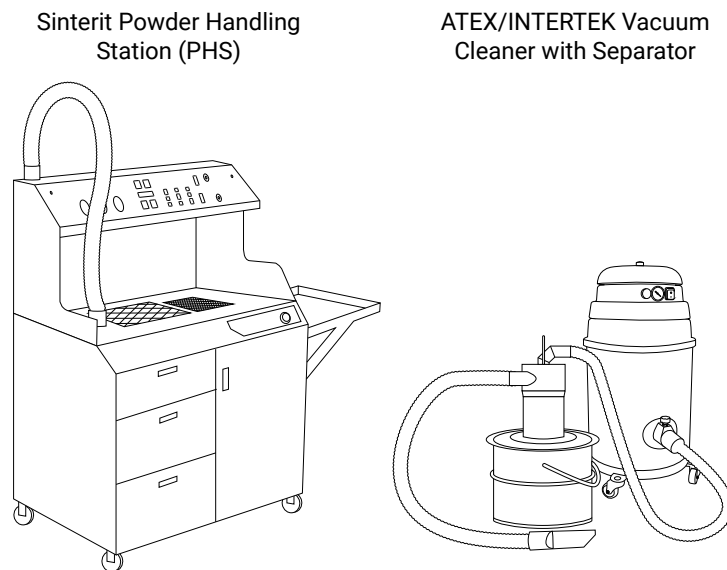

Fig. 9.2 Dedicated Sinterit solutions for cleaning the printer.



DANGER!

The vacuum cleaner used to collect the powder must be suitable for handling combustible dust. Sinterit recommends the ATEX/INTERTEK Vacuum Cleaner available in the offer.

- 4. If you have the PHS connected to the printer, a corresponding message will appear on the screen. Turn on depowdering program and press **DONE** on the screen (fig. 9.3)

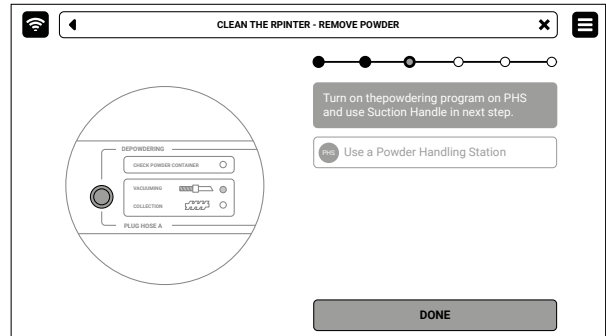

Fig. 9.3 Turn on the depowdering program on the PHS.

- 5. Whether you are using the PHS or an ATEX/INTERTEK Vacuum Cleaner with a Separator, a message about cleaning the print chamber will appear (fig. 9.4).
- 6. Collect the remaining powder in the print chamber with the suction hose with dedicated nozzles.
- 7. Press the arrow buttons to move the Recoater and collect the remaining powder underneath (fig. 9.4).
- 8. Once the print chamber is clean, press **DONE**.

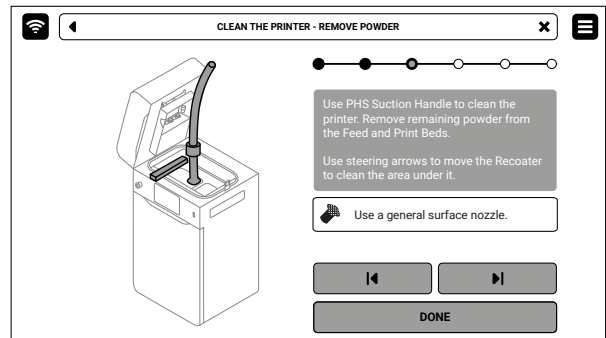
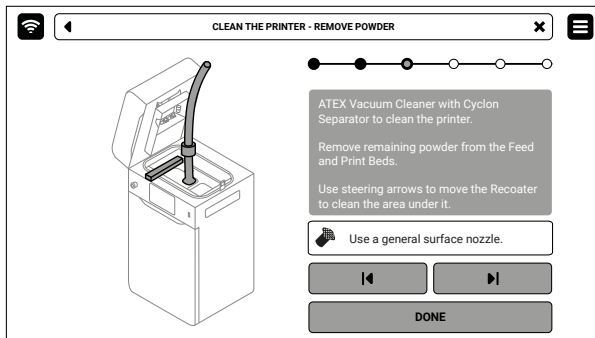
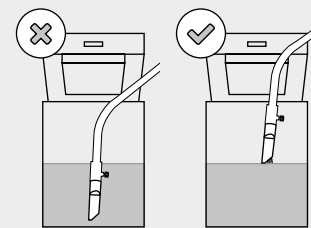

Fig. 9.4 Clean the print chamber using PHS or the ATEX vacuum cleaner with Separator.



IMPORTANT!

Keep the PHS/vacuum hose inlet just above the powder surface.





9.2 CLEANING THE OVERFLOW CONTAINER

1. Press **UNLOCK DOOR**, to open the printer door.
2. Press the **UNLOCK OVERFLOW** button to release the electrolock (fig. 9.5).
3. Slide out the overflow container.

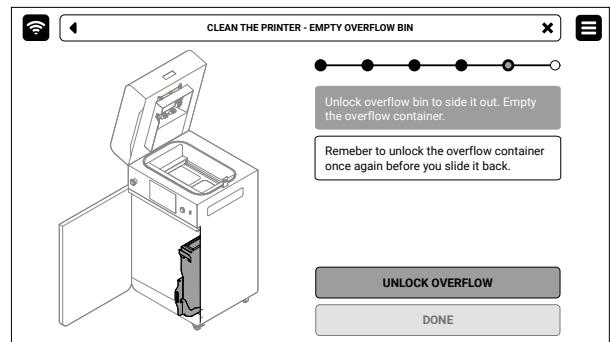

Fig. 9.5 Remember! Unlock Overflow container on the screen before sliding it out.



IMPORTANT!

After 10 seconds the electrolock will activate and it will no longer be possible to slide out the overflow container. If you still want to slide out the overflow container, press the **UNLOCK OVERFLOW** button again on the printer screen.

4. Slide out the overflow container (fig. 9.6).
5. Take the overflow container from its drawer and transfer its content onto the PHS worktop or into the metal container.
6. Put the overflow container back in its drawer.

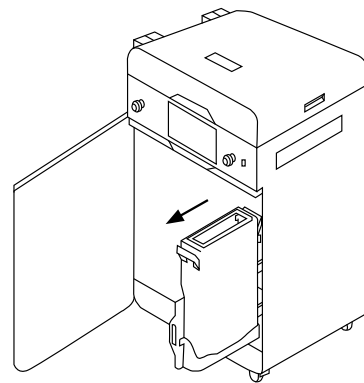

Fig. 9.6 Sliding out the overflow container.



IMPORTANT!

Make sure the overflow container is oriented correctly once you put it back. Pay attention to the markings on the container.



ATTENTION!

Attempting to slide the overflow container back into the printer without unlocking the security system may damage the drawers mechanisms.

7. Press the **UNLOCK OVERFLOW** button to release the lock and slide the drawer back into the printer.
8. Close the printer door and press **DONE**.
9. If you want to know how much fresh powder you need to add to the used powder press **SHOW REFRESH INFO**. If you wish to instead do that another time, press **SKIP**.



10. Printing with speciality powders

Some powders used in the Sinterit Lisa X printer need a protective atmosphere. In this situation, an inert gas connection is required. Powders in the Sinterit range that require an inert gas connection are PA11 Onyx, Pa11 CF and PA11 ESD.

	<p>WARNING!</p> <ul style="list-style-type: none">• The Lisa X printer with the inert gas installation should only be operated in a well-ventilated space.• Do not inhale the gas.• Danger of unsealing – inert gasses displace oxygen from the air. Low enough oxygen concentrations may cause loss of consciousness or even death by asphyxiation.	
--	---	--

1. Connect the source of inert gas to the gas inlet nipple on the back of the printer. It is a quick connect fitting (fig. 10.1).
2. On the main menu screen, in the **SETTINGS** tab, go to **MORE OPTIONS**.
3. Under the **ACCESSORIES** tab, switch to ON next to **INERT GAS** (fig. 10.2).
4. Start the printing process. The process is no different than the process outlined in Chapters 6-9.

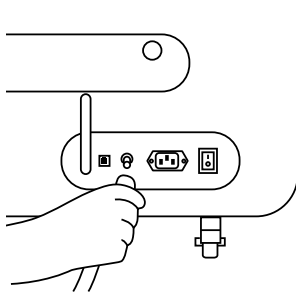

Fig. 10.1 Connecting the inert gas source.

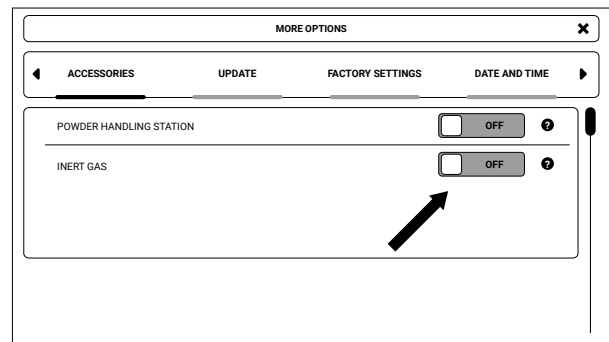





Fig. 10.2 **INERT GAS** activation in the printer.

	<p>IMPORTANT!</p> <ul style="list-style-type: none">• The inert gas source may safely be connected even if the printer is turned off. The connection is equipped with an electronic safety valve.• Make sure that the inert gas pressure remains between 4 and 8 [bar] / 58 to 116 [psi] throughout the whole process. Please note that it may fluctuate if a gas tank and a pressure regulator are in use.
--	---



11. Powder refreshment

Powder refreshment is a process that restores the initial properties of the powder that is recovered from the printing.

	<p>IMPORTANT!</p> <ul style="list-style-type: none"> • Every SLS powder recovered in the printing process requires sifting. • Not every SLS powder recovered in the printing process requires adding fresh powder. • For detailed information please refer to the specifications of the specific SLS powder. You can find them on our website www.sinterit.com.
	<p>IMPORTANT!</p> <p>Information about how much fresh powder needs to be added in the refresh process will be displayed on the printer screen after the printer cleaning step and also generated in a report from Sinterit Studio.</p>
	<p>ATTENTION!</p> <p>Always wear appropriate personal protective equipment when working with powder: clothing, goggles, mask, and gloves. You will find a suitable kit in the Dedicated Powder Tools package.</p>

11.1 POWDER REFRESHMENT WITH PHS

	<p>IMPORTANT!</p> <p>If the SLS powder you recovered from the printing process does not require adding fresh powder, skip steps 3-7.</p>
---	---

1. After the PHS has finished sifting the powder, remove the metal container from the PHS sifting module.
2. Insert an empty metal container into the sifting module.
- | | |
|---------------------|--|
| Adding fresh powder | <ol style="list-style-type: none"> 3. Prepare an appropriate portion of fresh powder. 4. Add prepared fresh powder to the sifted powder in the metal container. 5. Close the metal container with the lid and lock clamping ring. 6. Shake the metal container with the powder for at least 15 seconds to mix the powders. 7. Wait about 10 minutes for the powder in the metal container to settle and naturally de-electrify. Open the metal container. |
|---------------------|--|
8. Place the powder funnel (from Dedicated Powder Tools) over the metal container and lock the clamping ring.
9. Pour the mixed powder onto the PHS worktop above the powder chamber.
10. Press the **DEPOWDERING** button on the PHS control panel.
11. Make sure the HOSE A is connected to the vacuum cleaner.
12. Press the **DEPOWDERING** button again on the PHS control panel.
13. **CHECK POWDER CONTAINER** starts flashing. Open the door and make sure that the metal container is in its place and it is empty.
14. Close the PHS door.



15. Wait until all the powder is removed from the powder chamber.
16. Hold down the **DEPOWDERING** button for 3 seconds to start the powder sifting process.
17. The timer will start counting down 25 min. After this time, the powder sifting will be finished.
18. Repeat steps 1-2, 8-17 three times (skip adding fresh powder) to make sure the powder is thoroughly mixed and sifted.
19. The received powder is ready to use. Remember to store the powder in a tightly closed metal container.

11.2 POWDER REFRESHMENT WITH POWDER SIEVE OR METAL STRAINER



IMPORTANT!

If the SLS powder you recovered from the printing process does not require adding fresh powder, skip steps 2-6.

1. Sift the unsintered powder that remains after the printing process. Use the Powder Sieve or the metal strainer included in the Dedicated Powder Tools.

Adding
fresh powder

2. Prepare an appropriate portion of fresh powder.
3. Add prepared fresh powder to the sifted powder in the metal container.
4. Close the metal container with the lid and lock clamping ring.
5. Shake the metal container with the powder for at least 15 seconds to mix the powders.
6. Wait about 10 minutes for the powder in the metal container to settle and naturally de-electrify. Open the metal container.

7. Place the powder funnel (from Dedicated Powder Tools) over the metal container and lock the clamping ring.
8. Carefully pour the prepared powder onto a removable metal sieve (part of the Sieve) or sift through a metal strainer.
9. Make sure there is an empty metal container inside the Sieve.
10. Close the Sieve lid and turn on the unit.
11. Wait until all the powder is sifted.
12. Remove the metal container with the sifted powder from the Sieve.
13. Repeat steps 1, 7-12 three times (skip adding fresh powder) to make sure the powder is thoroughly mixed and sifted.
14. The received powder is ready to use. Remember to store the powder in a tightly closed metal container.



12. Basic maintenance



ATTENTION!

Any assembly, installation, adjustment and service work should be carried out with the device free of hazardous substances, including powder and dust in a NOT-CLASSIFIED atmosphere (an area with a non-potentially explosive atmosphere).

12.1 BASIC MAINTENANCE

- To determine if it is time to service the printer components, from the Main Menu, select **MAINTENANCE** and then select **PRINTER STATUS**.

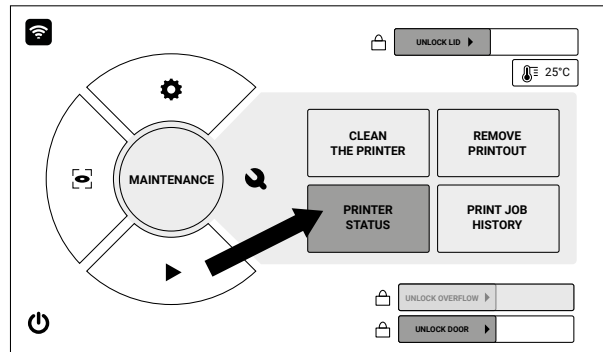

Fig. 12.1 The **MAINTENANCE** and **PRINTER STATUS** screen, which contains all the basic printer maintenance.

- The **PRINTER STATUS** screen includes:

- PRINTER STATUS** tab, in which you can check the current status of the printer and the condition of the printer components (fig. 12.2). Components requiring maintenance and cleaning are:
 - Laser protective glass
 - Recoater cord
 - Print Bed sealing
 - Feed Bed sealing
 - F-Theta scanning lens
 - Reflector sealing
 - Recoater drive cord
 - Infrared bulbs
 - Recoater roller.
- SELF CHECK** tab, in which it is possible to check that all components in the printer are working correctly (motors, laser, heaters, etc. Fig. 12.3).
- ERRORS** tab, in which you will see possible errors and messages of damage to printer components (fig. 12.4).

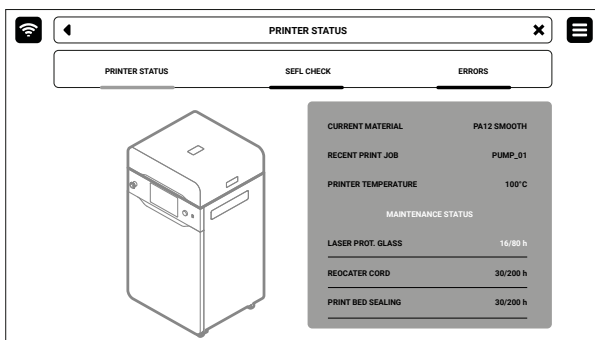

Fig. 12.2 The **PRINTER STATUS** screen.

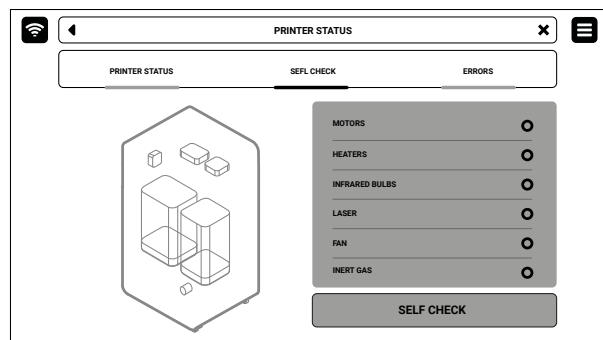

Fig. 12.3 The **SELF CHECK** screen

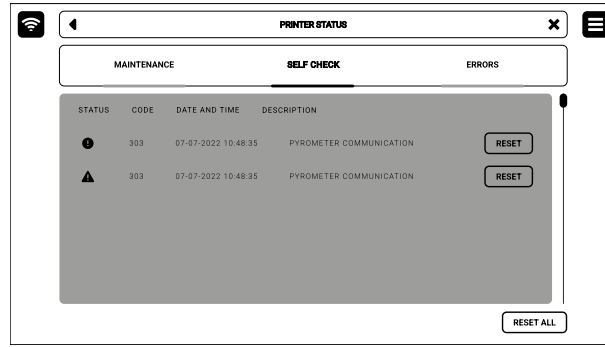

Fig. 12.4 The **ERRORS** screen.



ATTENTION!

Maintenance must always be performed by qualified technicians who are trained in the tasks they perform.



ATTENTION!

Remember to perform regular machine maintenance. Exceeding the time indicated by the counters can have a negative effect on the quality of printouts and even cause damage to the machine.



ATTENTION!

Before performing any maintenance:

- make sure you have carefully read the directions in this manual and know how the printer works,
- make sure that no unauthorised people are in the work area,
- make sure the necessary tools are available and that they are in a good condition,
- make sure there is sufficient lighting, and if necessary, provide portable 24-volt lamps.

Use of unsuitable tools or tools in poor condition can cause serious damage.



ATTENTION!

Before performing any maintenance work, always wear appropriate protective clothing, goggles, face mask and/or gloves appropriate to the type of work being performed.



IMPORTANT!

If you have any questions, please contact our After-sales team. For more information, please visit our website www.sinterit.com under the support section.



12.2 CLEANING THE PYROMETER WINDOW

You will need: 2 x cotton cloth, 2% salicylic spirits (ethanol solution) or another ethanol-based cleaning solution.

1. Choose **UNLOCK LID** on the printer screen.
2. Push on the lid and pull it up using the lid handle.



IMPORTANT!

After 10 seconds the electrolock will reactivate and it will no longer be possible to lift the lid. If you still want to open the printer, slide the **UNLOCK LID** button again on the printer screen.

3. Delicately wipe the pyrometer window with a cotton cloth soaked in 2% salicylic spirits (ethanol solution) or another ethanol-based cleaning solution. You may also use cleaning wipes provided in Dedicated Powder Tools.
4. Wipe the pyrometer window again with a dry cotton cloth, in order to remove any alcohol residue.

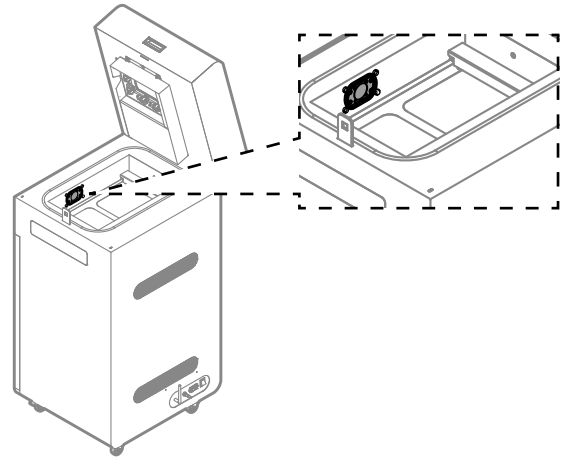

Fig.12.5 Location of the pyrometer in the print chamber.



IMPORTANT!

Do not use isopropyl alcohol to clean the pyrometer window!

12.3 CLEANING THE LASER PROTECTIVE GLASS



ATTENTION!

If the laser protective glass is damaged (visible scratches, cracks), replace it with a new one.



ATTENTION!

It is necessary to clean the laser protective glass immediately after each printing of rubber-like materials.



ATTENTION!

Beware of sharp edges.



STOP!

- Be careful not to damage the heating module.
- Do not clean the laser protective glass under running water.
- Do not clean the laser protective glass above the print chamber.
- Note any remaining lint on the surface of the glass after cleaning.

You will need: 2 x cotton cloth, 2% salicylic spirits (ethanol solution) or another ethanol-based cleaning solution.

1. On the **PRINTER STATUS** tab, select the **Laser protective glass** position (fig. 12.6).
2. The laser protective glass maintenance tab will appear on the screen. You can use the step-by-step guide (press **FOLLOW GUIDE**) or perform the cleaning yourself.
3. In this case, mark **MAINTENANCE DONE** once you have completed the cleaning procedure, and then the **DONE** button. The timer will reset to zero (fig. 12.7).

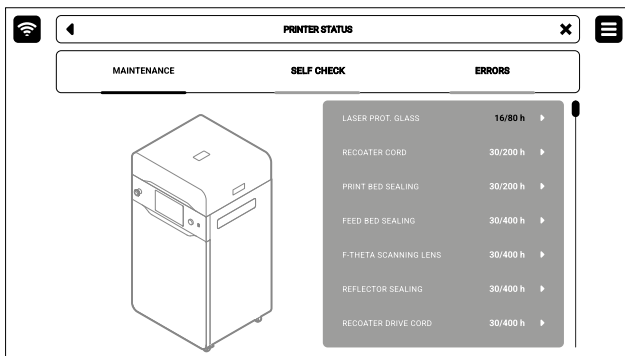

Fig. 12.6 Select **Laser protective glass** position to start the maintenance.

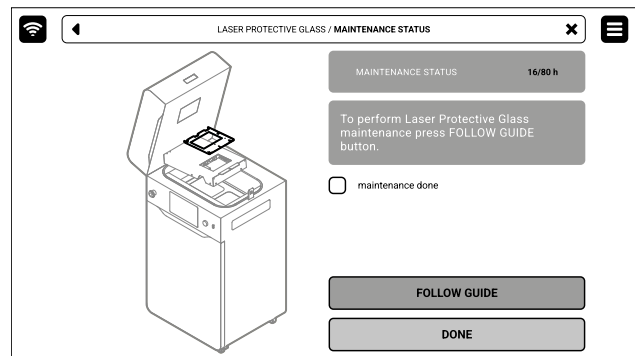

Fig. 12.7. The screen of the maintenance of the laser protection glass.

4. Choose **UNLOCK LID** on the screen.
5. Push on the lid and pull it up using the lid handle. Remember, you only have 10 seconds to open it before the lock activates again.
6. Remove the split pin from the heating module.
7. Lower the heating module.
8. Unscrew two quick release nuts. Make sure you hold the laser protective glass, otherwise it may fall.
9. Take the laser protective glass out.
10. Delicately wipe the glass on both sides with a cotton cloth soaked in 2% salicylic spirit (ethanol solution) or another ethanol-based cleaning solution. You may also use cleaning wipes provided in Dedicated Powder Tools.



IMPORTANT!

Do not use isopropyl alcohol to clean the laser protective glass.



IMPORTANT!

Cleaning the laser protective glass after printing from rubber-like materials requires the use of agents containing isobutanol and methyl ethyl ketone, xylene and toluene.

11. Wipe the glass again on both sides with a dry cotton cloth.
12. Slide the metal tabs of the laser protective glass into the mounting brackets below the laser module.
13. Lock the laser protective glass in place by mounting and tightening the two quick release nuts.
14. Lift the heating module.
15. Reinsert the heating module split pin.



16. Good job. The maintenance timer will reset to zero.

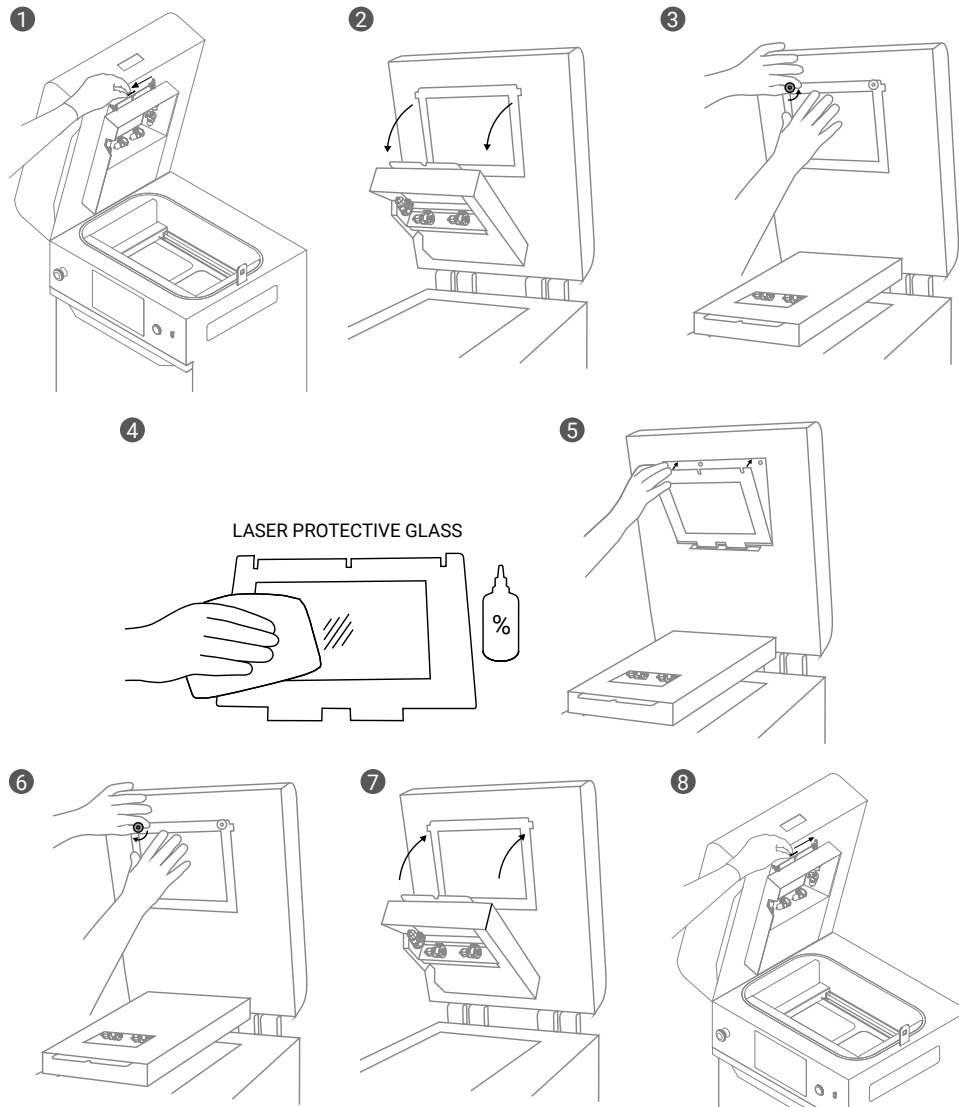

Fig. 12.8 Cleaning the laser protective glass.

12.4 REPLACING RECOATER CORD

You will need: 2 mm allen key, brush or compressed air, new Recoater cord.

1. On the **PRINTER STATUS** tab, select the **Recoater CORD** position (fig. 12.9)
2. The Recoater cord maintenance tab will appear on the screen. You can use the step-by-step guide (press **FOLLOW GUIDE**) or perform the replacement yourself.
3. In this case, mark **MAINTENANCE DONE** once you have completed the procedure, and then the **DONE** button. The timer will reset to zero (fig. 12.10).

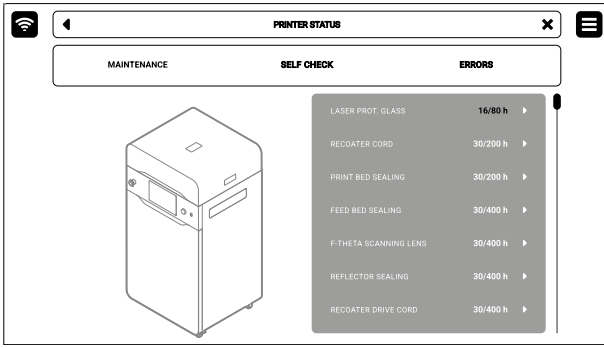

Fig. 12.9 Select the **Recoater CORD** position to start the maintenance.

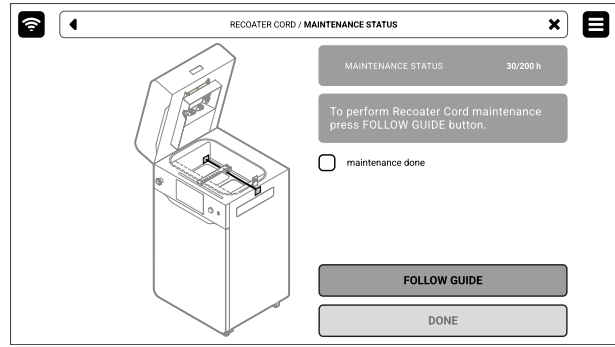

Fig. 12.10 The screen of the maintenance of the Recoater cord.

4. Choose **UNLOCK LID** on the screen.
5. Push on the lid and pull it up using the lid handle. Remember, you only have 10 seconds to open it before the lock activates again.
6. Clean the print chamber if needed.
7. Use the steering arrows to position the Recoater between the Beds.
8. Using a 2 mm allen key, unscrew both screws on the Recoater cover and take off it (fig. 12.11).
9. Gently remove the black cover from Recoater (fig. 12.12).

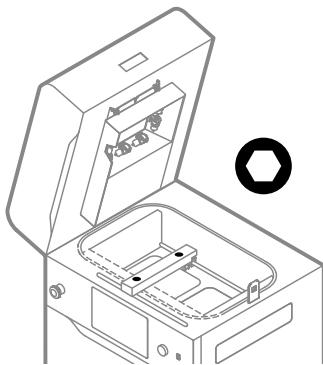

Fig. 12.11 Set the Recoater and remove the screws from the Recoater cover.

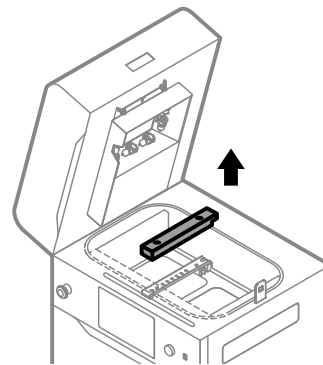

Fig. 12.12 Remove the black Recoater cover.

10. Clean all screw heads thoroughly.
11. Using a 2 mm allen key, unscrew the screws on the Recoater cord mounting plate on the left and right side (fig. 12.13).
12. If access to the screws is problematic, use the steering arrows to move the Recoater in the right direction.

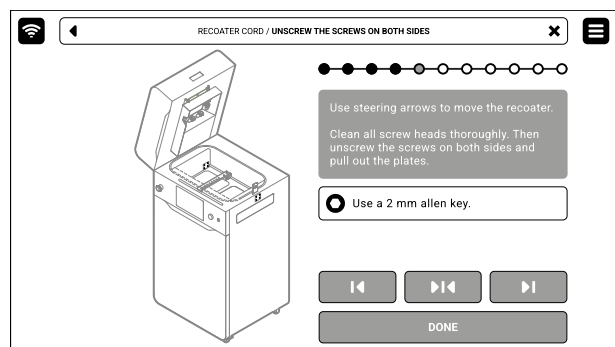

Fig. 12.13 Unscrew the screw of the Recoater cord.



13. Grab the cord from both sides and remove it from the knurled roller wheel.
14. Drag out the end of the cord (without spring) above the Recoater's roller. At first the mounting plate, then the ending, through the gap between the rotary shaft and Recoater housing. Be careful not to touch the roller (fig. 12.14).
15. Remove the second plate (with spring) from the socket.
16. Use a clean cloth to wipe the Recoater rotary shaft. Rotate the roll during the cleaning.
17. Take the new Recoater cord and stretch it before mounting.
18. Pre-install the plate with the spring on the Print Bed side. Be sure that the spring is fitted into the hole behind the plate. Do not tighten the screws to the end of the range (fig. 12.15).

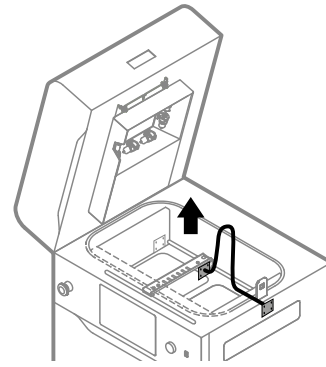

Fig. 12.14 Drag out the plate without spring above the Recoater's roller.

19. Drag the other end of the Recoater cord above the Recoater roller.
20. Wind the Recoater cord on the roller tracing wheel (fig. 12.15).
21. Check if anything is blocking the slide of the cord.
22. Pull the cord to tense the spring.

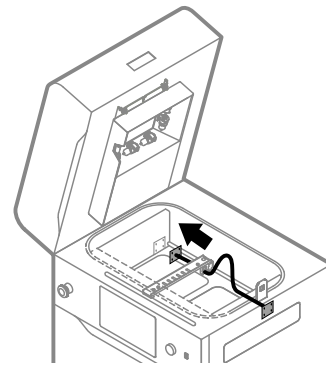

Fig. 12.15 Installing a new Recoater cord.

23. Mount the cord using screws on the opposite side (fig. 12.16).
24. Tighten all the screws from both sides. If access to the screws is problematic, use the steering arrows to move the Recoater in the right direction.
25. After mounting the cord use steering arrows to move the Recoater.
26. Check if the rotary shaft is rolling properly. Correct installed cord is moving slightly right and left on the bearing system.

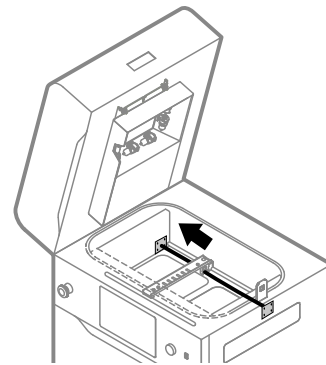

Fig. 12.16. Installing a new Recoater cord.

27. Reinstall the black Recoater cover (fig. 12.17).
28. Tighten the screws securing the black Recoater cover.
29. Good job. The maintenance timer will reset to zero.

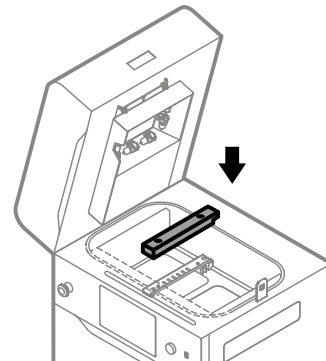

Fig. 12.17 Reinstall the black Recoater cover and tighten the screws.



12.5 REPLACING PRINT BED SEALING



ATTENTION!

Always wear appropriate personal protective equipment when working with powder: clothing, goggles, mask, and gloves. You will find a suitable kit in the Dedicated Powder Tools package.

You will need: 2,5 mm allen key, ATEX/INTERTEK vacuum cleaner, compressed air, metal spatula, plastic spatula, scissors, new fibreglass rope.

1. On the **PRINTER STATUS** tab, select the **PRINT BED SEALING** position.
2. The Print Bed sealing maintenance tab will appear on the screen. You can use the step-by-step guide (press **FOLLOW GUIDE**) or perform the replacement yourself.
3. In this case, mark **MAINTENANCE DONE** once you have completed the procedure, and then the **DONE** button. The timer will reset to zero (fig. 12.18).

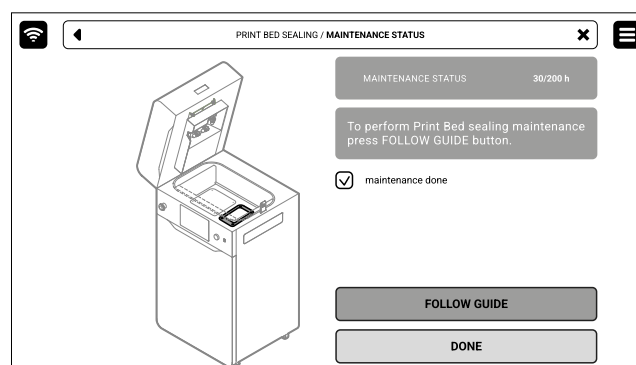

Fig. 12.18 The screen of the maintenance of the Print Bed sealing.

4. Choose **UNLOCK LID** on the screen.
5. Push on the lid and pull it up using the lid handle. Remember, you only have 10 seconds to open it before the lock activates again.
6. Make sure the print chamber is free of any unwanted items that may interfere with moving the Recoater. Clean the print chamber if needed.
7. Press **POSITION BEDS** to begin the positioning process of the Beds (fig. 12.19).
8. Once the positioning process is finished, both Beds should be in their topmost position. Remember! Do not close the lid!

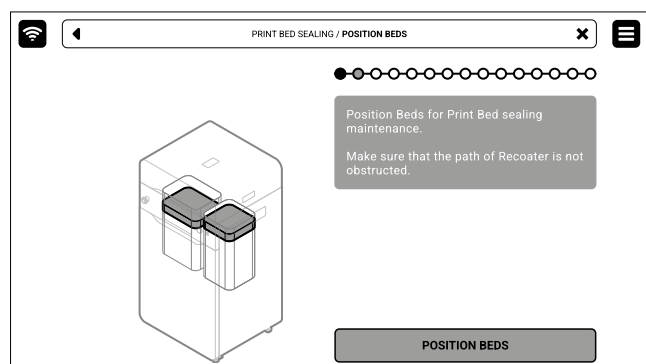

Fig. 12.19. **POSITIONING BED** screen.

9. Press **UNLOCK DOOR** on the screen and open the printer door.
10. Check the amount of powder under the Print Bed. If the powder layer is thin and smooth - press the **MAINTENANCE DONE** button (fig 12.20).
11. If the powder layer has formed a mound - press the **REPLACE SEALING** button (fig. 12.20).

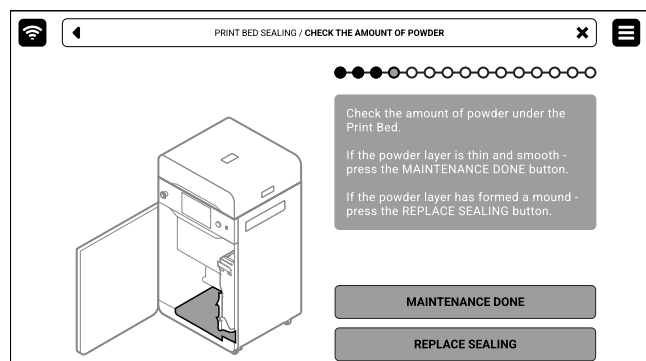

Fig. 12.20 Check the amount of powder under the Beds.



12. Choose the right nozzle and vacuum the surface under the Beds thoroughly. Press the **DONE** button.
13. Close the printer door and press the **DONE** button.

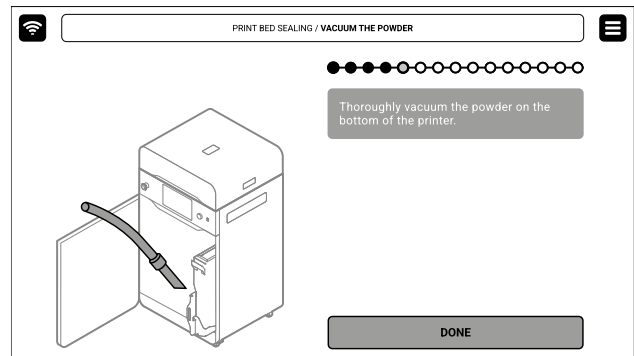

Fig. 12.21 Vacuum the powder on the bottom of the printer.



ATTENTION!

Vacuum the space under the Beds carefully!
Above are the beds' motors, which can be damaged during cleaning.

14. In the print chamber, clean Print Bed thoroughly, especially screw heads.
15. Using a 2,5 mm allen key, unscrew and remove four screws securing the Print Bed cover (fig. 12.22).
16. Remove the Print Bed cover. You can use the metal spatula (from Dedicated Powder Tools) to pry up and remove the cover (fig. 12.23).

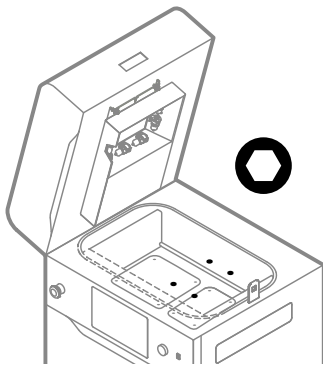

Fig. 12.22 Unscrew the Print Bed screws.

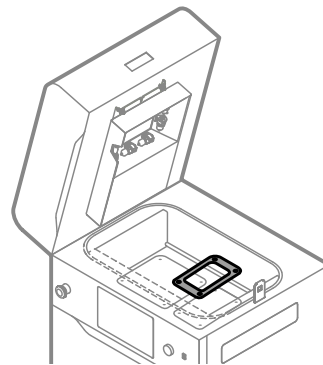

Fig. 12.23 Remove the Print Bed cover.

17. Remove the used fiberglass rope around the Print Bed. You can use the metal spatula to help pull out the sealing (fig. 12.24).
18. Vacuum powder from the Print Bed and the gap around. Use appropriate nozzles (fig. 12.25).

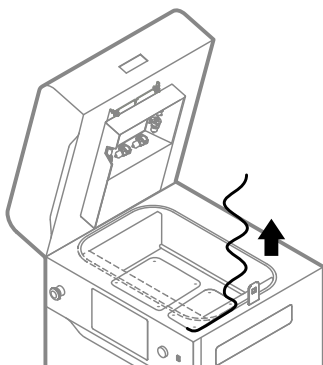

Fig. 12.24 Remove the used fiberglass rope from Print Bed.

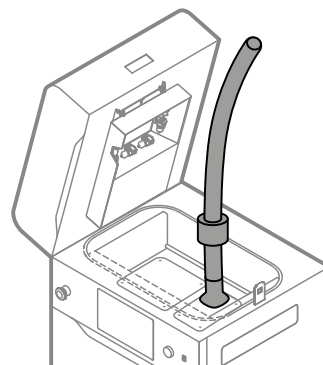

Fig. 12.25 Vacuum powder from Print Bed.

19. Put on a new fiberglass rope by wrapping it two times around the Print Bed. Remember not to stretch the fiberglass rope (fig. 12.26).



20. Use a clean, plastic spatula while pressing down the fibreglass rope (fig. 12.27).
21. Finish sealing at the starting point. Using scissors cut off excess fibreglass cord.

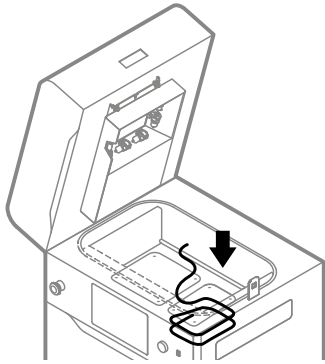

Fig. 12.26 Put on new fibreglass sealing.

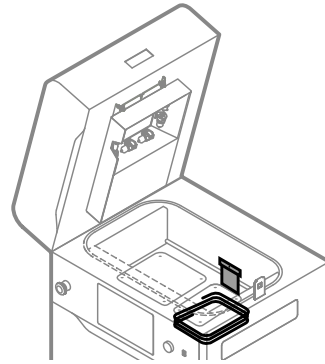

Fig. 12.27 Use a plastic spatula to press down the sealing.

22. Put on the Print Bed cover (fig. 12.28).
23. Using a 2,5 mm allen key, tighten the four screws securing the Print Bed cover (fig. 12.29).

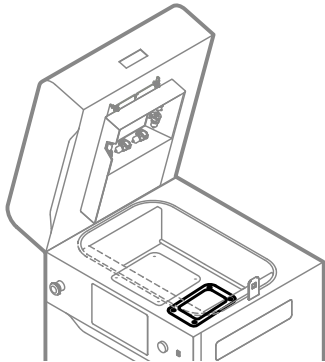

Fig. 12.28 Put on the Print Bed cover.

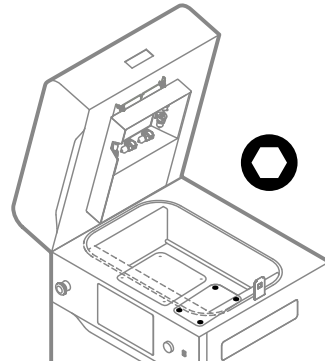

Fig. 12.29 Tighten the four screws securing the Print Bed cover.

24. Good job. The maintenance timer will reset to zero.



12.6 REPLACING FEED BED SEALING



ATTENTION!

Always wear appropriate personal protective equipment when working with powder: clothing, goggles, mask, and gloves. You will find a suitable kit in the Dedicated Powder Tools package.

You will need: 2,5 mm allen key, ATEX/INTERTEK vacuum cleaner, compressed air, metal spatula, plastic spatula, scissors, new fiberglass rope.

1. On the **PRINTER STATUS** tab, select the **FEED BED SEALING** position.
2. The Feed Bed sealing maintenance tab will appear on the screen. You can use the step-by-step guide (press **FOLLOW GUIDE**) or perform the replacement yourself.
3. In this case, mark **MAINTENANCE DONE** once you have completed the procedure, and then the **DONE** button. The timer will reset to zero (fig. 12.30).

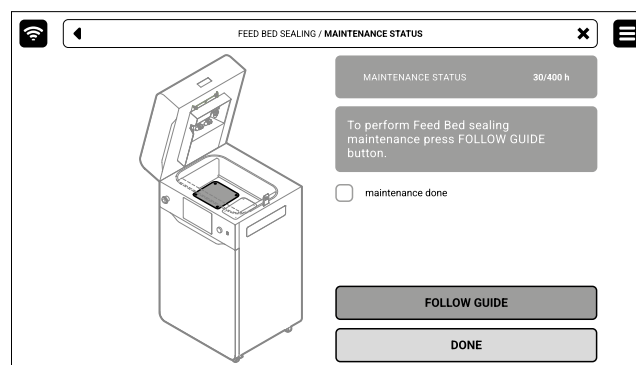

Fig. 12.30 The screen of the maintenance of the Feed Bed sealing.

4. Choose **UNLOCK LID** on the screen.
5. Push on the lid and pull it up using the lid handle. Remember, you only have 10 seconds to open it before the lock activates again.
6. Make sure the print chamber is free of any unwanted items that may interfere with moving the Recoater. Clean the print chamber if needed.
7. Press **POSITION BEDS** to begin the positioning process of the Beds (fig. 12.31).
8. Once the positioning process is finished, both Beds should be at maximum at the top. Remember! Do not close the lid!

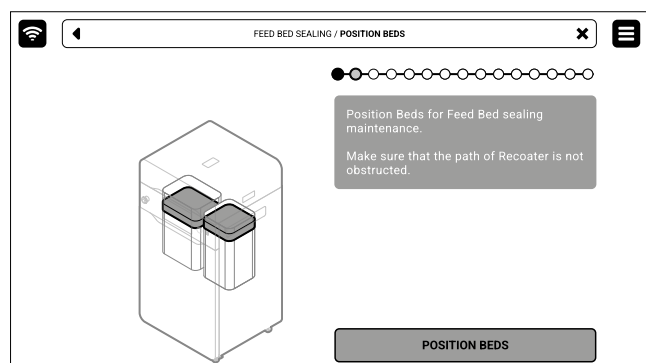

Fig. 12.31. **POSITIONING BED** screen.

9. Press **UNLOCK DOOR** on the screen and open the printer door.
10. Check the amount of powder under the Feed Bed. If the powder layer is thin and smooth - press the **MAINTENANCE DONE** button (fig 12.32).
11. If the powder layer has formed a mound - press the **REPLACE SEALING** button (fig. 12.32).

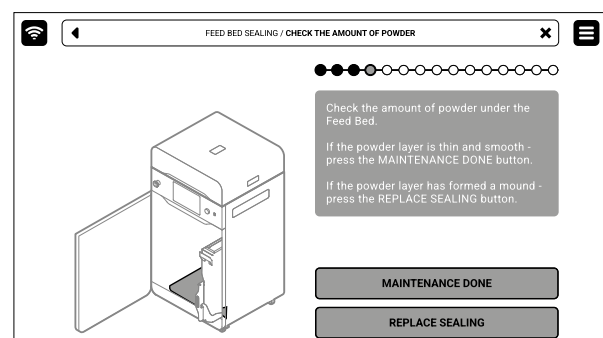

Fig. 12.32 Check the amount of powder under the Beds.



12. Choose the right nozzle and vacuum the surface under the Beds thoroughly. Press the **DONE** button.
13. Close the printer door and press the **DONE** button.

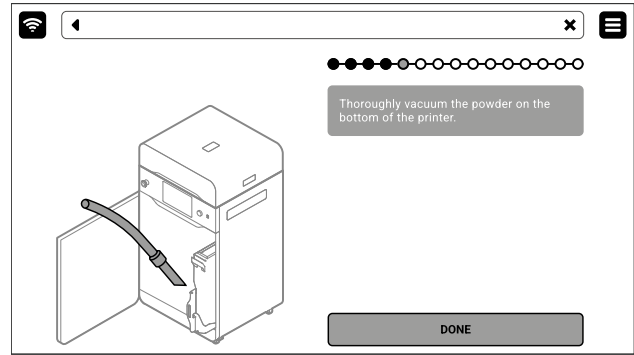

Fig. 12.33 Vacuum the powder on the bottom of the printer.



ATTENTION!

Vacuum the space under the Beds carefully!
Above are the Beds' motors, which can be damaged during cleaning.

14. In the print chamber, clean Feed Bed thoroughly, especially screw heads.
15. Using a 2,5 mm allen key, unscrew and remove four screws securing the Feed Bed cover (fig 12.34).
16. Remove the Feed Bed cover. You can use the metal spatula (from Dedicated Powder Tools) to pry up and remove the cover (fig. 12.35).

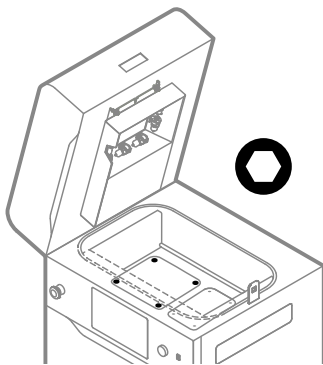

Fig. 12.34 Unscrew the Feed Bed screws.

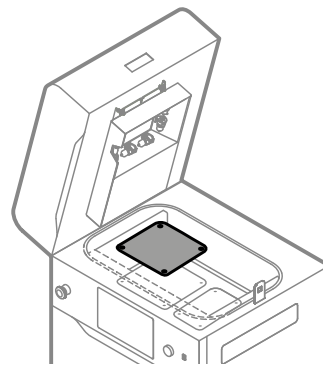

Fig. 12.35 Remove the Feed Bed cover.

17. Remove the used fibreglass rope around the Feed Bed. You can use the metal spatula to help pull out the sealing (fig. 12.36).
18. Vacuum powder from the Feed Bed. Use appropriate nozzles (fig. 12.37).

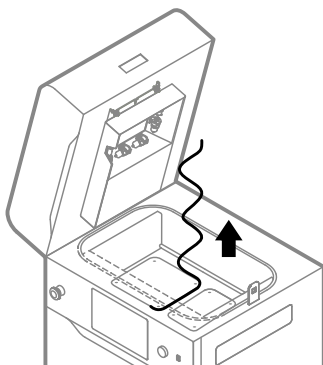

Fig. 12.36 Remove the used fibreglass rope from Feed Bed.

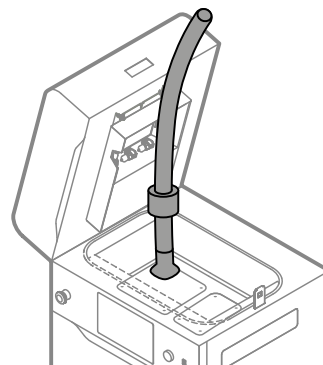

Fig. 12.37 Vacuum powder from Feed Bed.

19. Put on a new fibreglass rope by wrapping it two times around the Feed Bed. Remember not to stretch the fibreglass rope (fig. 12.38).
20. Use a clean, plastic spatula while pressing down the fibreglass rope (fig. 12.39).



21. Finish sealing at the starting point. Using scissors cut off excess fibreglass cord.

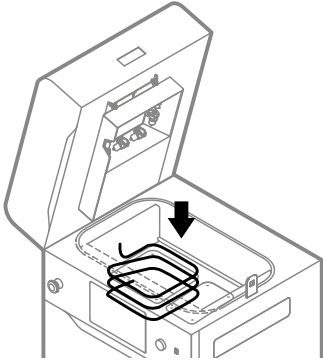

Fig. 12.38 Put on new fibreglass sealing.

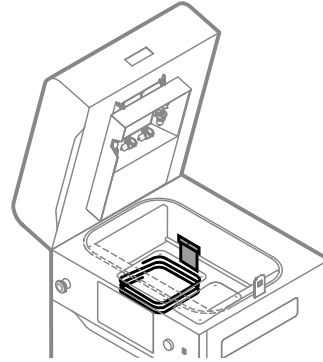

Fig. 12.39 Use a plastic spatula to press down the sealing.

22. Put on the Feed Bed cover (fig. 12.40).

23. Using a 2,5 mm allen key, tighten the four screws securing the Feed Bed cover (fig. 12.41).

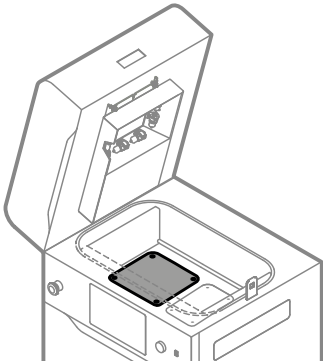

Fig. 12.40 Put on the Feed Bed cover.

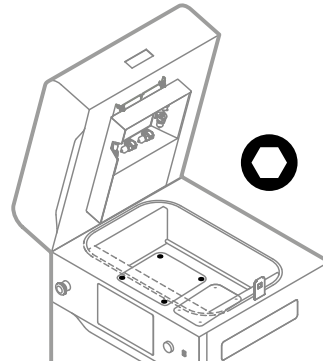

Fig. 12.41 Tighten the four screws securing the Feed Bed cover.

24. Good job. The maintenance timer will reset to zero.



12.7 CLEANING THE F-THETA SCANNING LENS



ATTENTION!

The F-Theta scanning lens is a very delicate component, and special care must be taken when cleaning it. Damage to the lens will result in the inability to print.



IMPORTANT!

Cleaning the F-Theta scanning lens must be carried out with the device switched off!

You will need: protective gloves, compressed air

1. On the **PRINTER STATUS** tab, select the **F-THETA SCANNING LENS** position.
2. Mark **MAINTENANCE DONE** to complete the cleaning procedure, and then the **DONE** button. The timer will reset to zero (fig. 12.42).

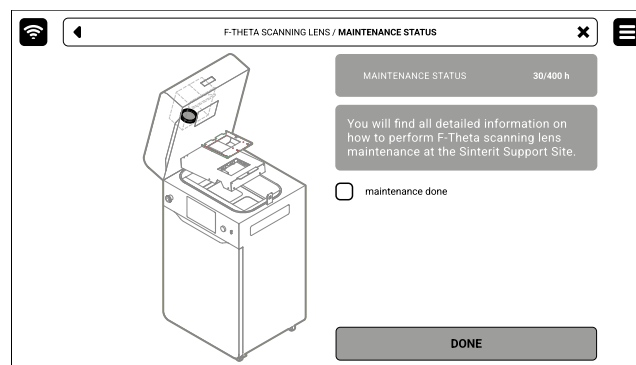

Fig. 12.42 The screen of the maintenance of the F-Theta scanning lens.

3. Back to the **MAIN MENU** screen.
4. Choose **UNLOCK LID** on the screen.
5. Push on the lid and pull it up using the lid handle. Remember, you only have 10 seconds to open it before the lock activates again.
6. Turn off the printer. Cleaning the F-Theta scanning lens must be carried out with the device switched off!
7. Put on the protective gloves.
8. Remove the split pin from the heating module (fig. 12.43.1).
9. Lower the heating module (fig. 12.43.2).
10. Unscrew two quick release nuts. Make sure you hold the laser protective glass, otherwise it may fall (fig. 12.43.3).

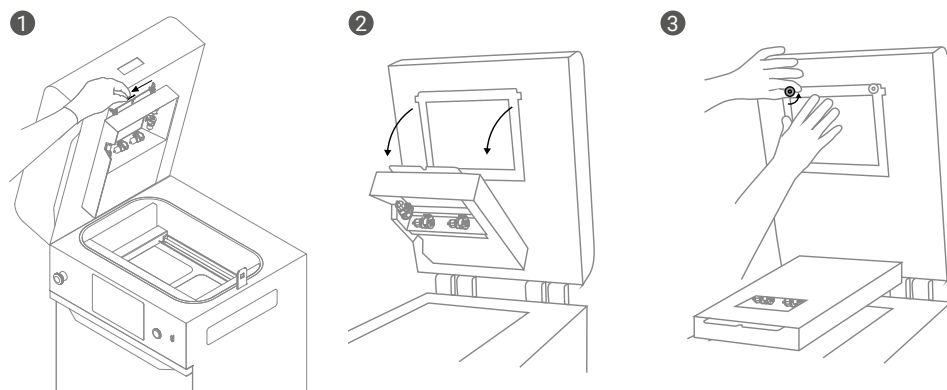

Fig. 12.43 Lower the heating module and remove the laser protective glass to access the F-Theta scanning lens.



11. Take the laser protective glass out to get access to the F-Theta scanning lens.
12. Use compressed air to clean the lens surface (fig. 12.44). Do not touch the lens with anything!

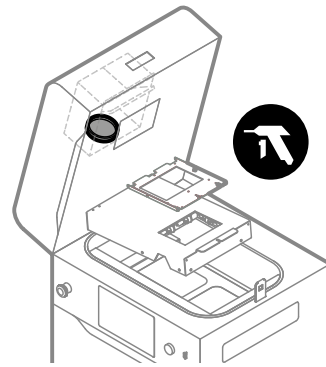

Fig. 12.44 Cleaning F-Theta scanning lens.

13. Insert the laser protective glass into mounting brackets and tighten the two quick release nuts (fig 12.45).

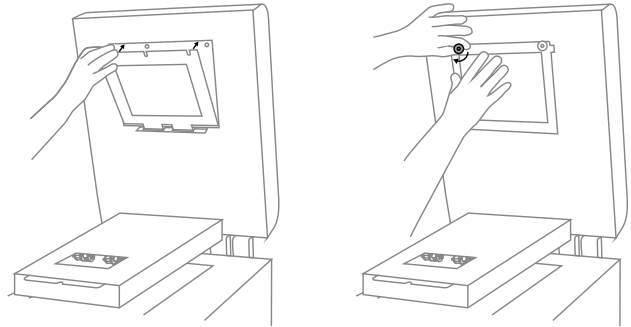

Fig. 12.45 Reinstall the laser protective glass and quick release nuts.

14. Lift the heating module (fig. 12.46).
15. Reinsert the heating module split pin (fig. 12.46).
16. Good job. The printer is ready to work again.

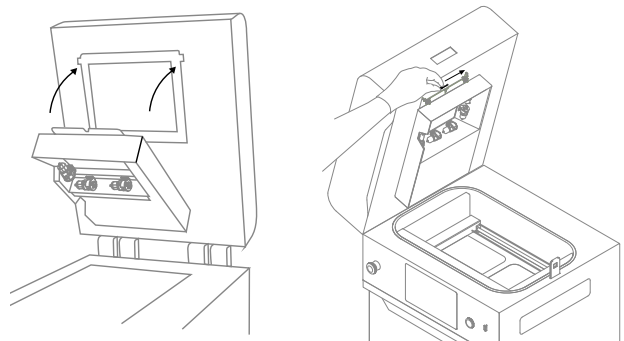

Fig. 12.46 Reinstall the heating module.



12.8 REPLACING REFLECTOR SEALING



IMPORTANT!

Replacing the reflector sealing must be carried out with the device switched off!

You will need: protective gloves, ethyl alcohol, cotton cloth, new reflector sealing

1. On the **PRINTER STATUS** tab, select the **REFLECTOR SEALING** position.
2. Mark **MAINTENANCE DONE** to complete the cleaning procedure, and then the **DONE** button. The timer will reset to zero (fig. 12.47).

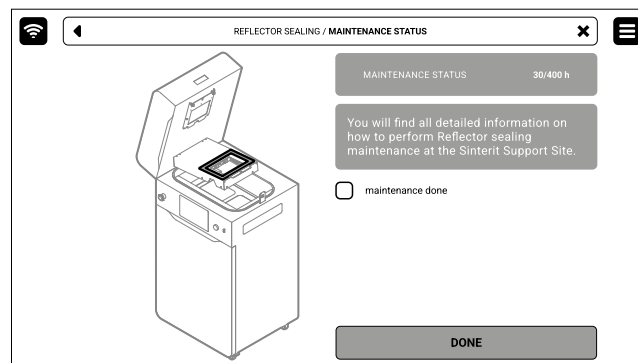

Fig. 12.47 The screen of the maintenance of the Reflector sealing.

3. Back to the **MAIN MENU** screen.
4. Choose **UNLOCK LID** on the screen.
5. Push on the lid and pull it up using the lid handle. Remember, you only have 10 seconds to open it before the lock activates again.
6. Turn off the printer. Replacing the reflector sealing must be carried out with the device switched off!
7. Put on the protective gloves.

8. Remove the split pin from the heating module (fig. 12.48).
9. Lower the heating module (fig. 12.48).

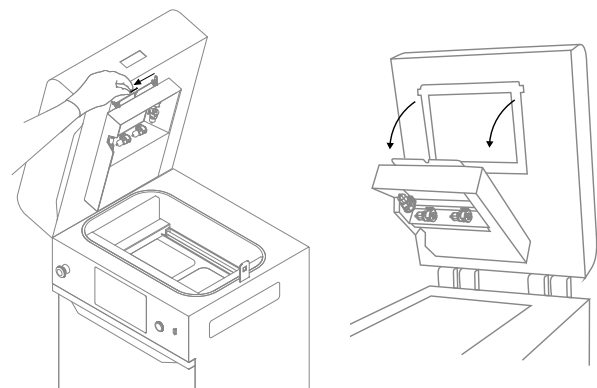

Fig. 12.48 Lower the heating module to access the reflector sealing.



10. The reflector sealing is located in the heating module (fig. 12.49). Check its condition for any damage, deformation or tearing. If needed, replace it.
11. Remove the old sealing.

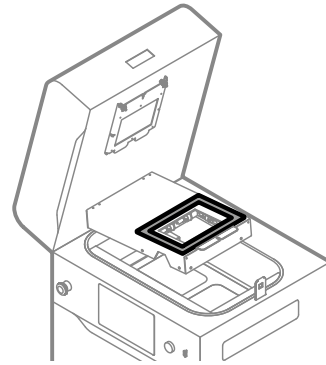

Fig. 12.49 Location of the reflector sealing.

12. Use a cotton cloth soaked in alcohol to remove the sealing residues (fig. 12.50).
13. Take the new reflector sealing.
14. Remove the plastic paper and place the sealing carefully around the hole (fig. 12.51). Do not stretch the seal when glueing!
15. Press the seal carefully on each side.

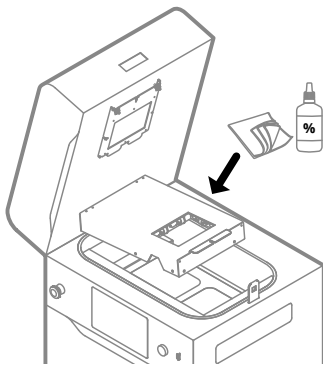

Fig. 12.50 Clean the reflector thoroughly before applying a new sealing.

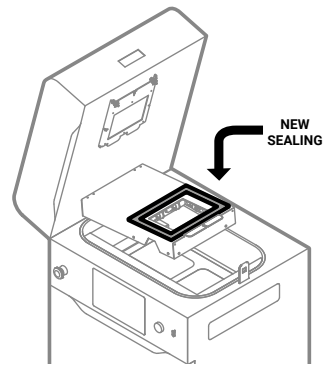

Fig. 12.51 Apply the new reflector sealing.

16. Lift the heating module (fig. 12.52).
17. Reinsert the heating module split pin (fig. 12.52).
18. Good job. The printer is ready to work again.

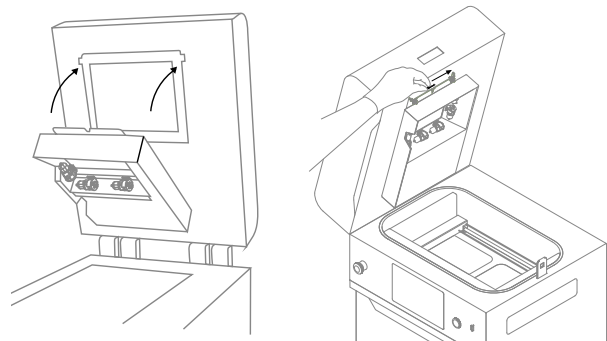

Fig. 12.52 Reinstall the heating module.



12.9 REPLACING INFRARED BULB



IMPORTANT!

- Replacement of Infrared bulbs must be carried out with the device switched off!
- To avoid burning your hands, only operate on a cooled-down device!

You will need: Protective gloves, clean cloth or paper towel, spare Infrared bulb(s)

Before each printout, the printer checks the condition of the components. If one of the Infrared bulbs is faulty, an error will appear. Printing is then not possible and the defective bulb(s) must be replaced.

1. To see which Infrared bulb needs replacing, go to **MAINTENANCE // PRINTER STATUS**, then **INFRARED BULBS**.
2. On the screen, a drawing will appear with the Infrared bulb(s) requiring replacement highlighted.
3. Mark the **MAINTENANCE DONE** and then the **DONE** button (fig. 12.53).

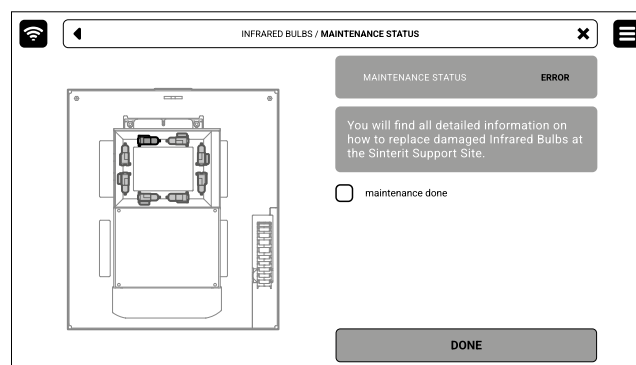

Fig. 12.53 The screen of the maintenance of the Infrared bulbs.

4. Back to the **MAIN MENU** screen.
5. Choose **UNLOCK LID** on the screen.
6. Push on the lid and pull it up using the lid handle. Remember, you only have 10 seconds to open it before the lock activates again.
7. Turn off the printer. Replacement of Infrared bulbs must be carried out with the device switched off!
8. Put on the protective gloves.
9. Make sure the Infrared bulbs are not hot.
10. Use a clean cloth or paper towel while replacing the infrared bulb. Do not touch it with your bare hands!
11. Gently grab the Infrared bulb with your fingers and remove it parallel to its slots. Do not twist it in any direction because it may cause damage to the heater's slots!
12. Take a new Infrared bulb and insert it to the slot. It will work regardless of the heater orientation.
13. Good job. The printer is ready to work again.



12.10 CLEANING RECOATER ROLLER



ATTENTION!

Always wear appropriate personal protective equipment when working with powder: clothing, goggles, mask, and gloves. You will find a suitable kit in the Dedicated Powder Tools package.

You will need: 2 mm allen key, PHS or ATEX/INTERTEK vacuum cleaner with separator, 2x cotton cloth, 2% salicylic spirits (ethanol solution) or another ethanol-based cleaning solution.

1. On the **PRINTER STATUS** tab, select the **RECOATER ROLLER - CLEAN** position.
2. The maintenance tab of the cleaning Recoater roller will appear on the screen. You can use the step-by-step guide (press **FOLLOW GUIDE**) or perform the replacement yourself.
3. In this case, mark **MAINTENANCE DONE** once you have completed the procedure, and then the **DONE** button. The timer will reset to zero (fig. 12. 54).

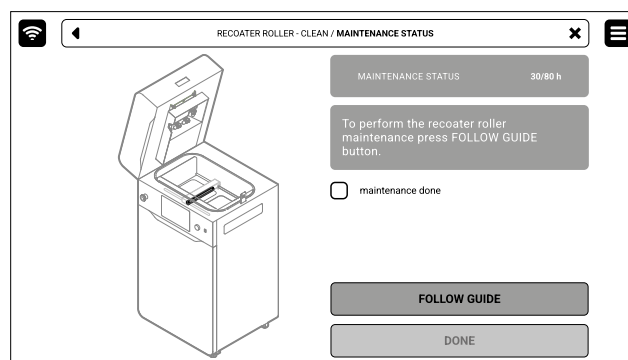

Fig. 12.54 The screen of the maintenance of the cleaning Recoater roller.

4. Choose **UNLOCK LID** on the screen.
5. Push on the lid and pull it up using the lid handle. Remember, you only have 10 seconds to open it before the lock activates again.
6. Use the steering arrows to position the Recoater in between the Beds.
7. Using a 2 mm allen key, unscrew both screws on the Recoater cover and take off it (fig. 12.55).
8. Gently remove the black cover from Recoater (fig. 12.56).

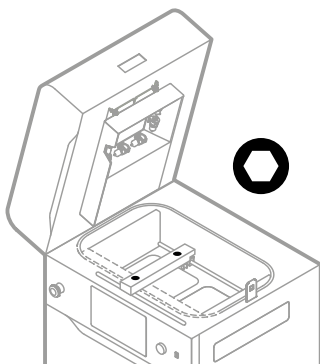

Fig. 12.55 Set the Recoater and remove the screws from the Recoater cover.

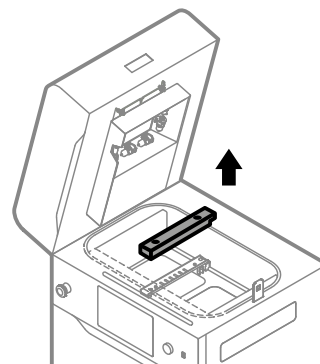

Fig. 12.56 Remove the black Recoater cover.

9. Use the PHS with Suction Handle (depowdering program) or the Powder Separator connected to the ATEX Vacuum Cleaner. Remove remaining powder from the Print and Feed Beds. Use steering arrows to move the Recoater to clean the area under it (fig. 12.57).

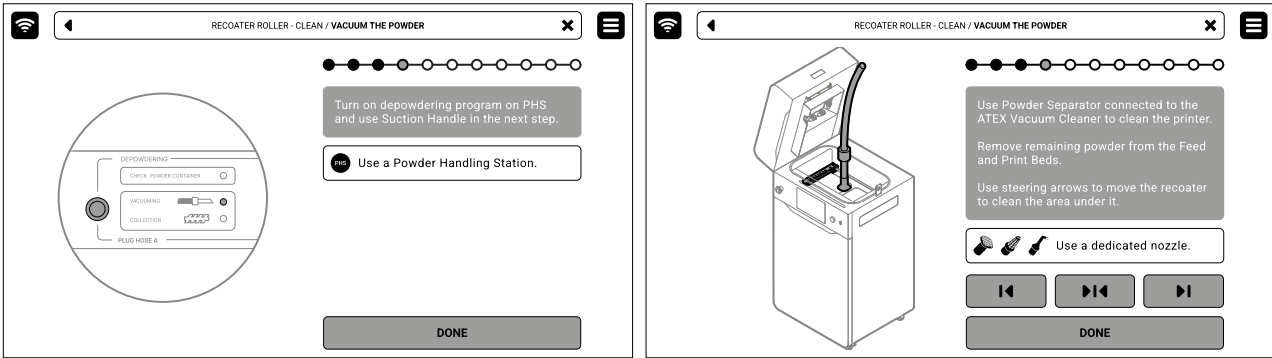

Fig. 12.57 Use PHS or Powder Separator with ATEX vacuum cleaner to clean the print chamber.

10. Press **POSITION BED** to begin the positioning process of the Feed Bed and Recoater.
11. When the positioning is finished, the Feed Bed should be at half its height and the Recoater above it.
12. Wipe the Recoater roller with dry cloth to remove the powder (fig. 12.58).
13. Next, wipe the Recoater roller using cloth soaked in ethyl alcohol (fig. 12.58). Press **DONE**.

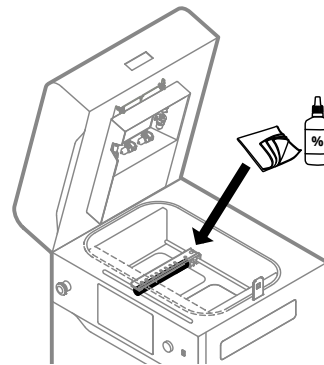

Fig. 12.58 Use the cloth and ethyl alcohol to clean the Recoater roller, when it is above the Feed Bed.

14. Press **POSITION BED** to begin the positioning process of the Print Bed and Recoater.
15. When the positioning is finished, the Print Bed should be at half its height and the Recoater above it.
16. Once again, wipe the Recoater roller with dry cloth to remove the powder (fig. 12.59).
17. Next, wipe the Recoater roller using cloth soaked in ethyl alcohol (fig. 12.59). Press **DONE**.

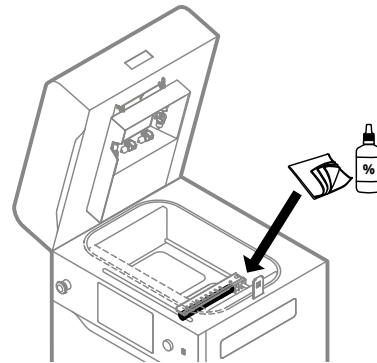

Fig. 12.59 Use cloth and ethyl alcohol to clean the Recoater roller, when it is above the Print Bed.

18. Reinstall the black Recoater cover (fig. 12.60).
19. Tighten the screws securing the black Recoater cover. Use a 2 mm allen key.
20. Good job. The maintenance timer will reset to zero.

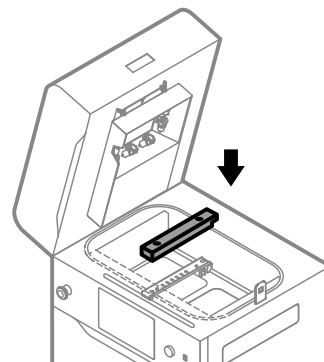

Fig. 12.60 Reinstall the black Recoater cover and tighten the screws.



12.11 CHECKING THE TENSION OF THE RECOATER DRIVE UNIT CORD (REV. A-B)

You will need: 2 mm allen key, 7 mm wrench, 10 mm torque wrench

Every approx. 400 hours is required to check the tension of the Recoater Drive Unit Cord. A properly tensioned cable is springy, with no curve, and under finger pressure, it flexes by about 0,5 cm.

1. On the **PRINTER STATUS** tab, select the **RECOATER DRIVE CORD** position.
2. The maintenance tab of the checking Recoater Drive Unit Cord will appear on the screen. You can use the step-by-step guide (press **FOLLOW GUIDE**) or perform the replacement yourself.
3. In this case, mark **MAINTENANCE DONE** once you have completed the procedure, and then the **DONE** button. The timer will reset to zero (fig. 12.61).

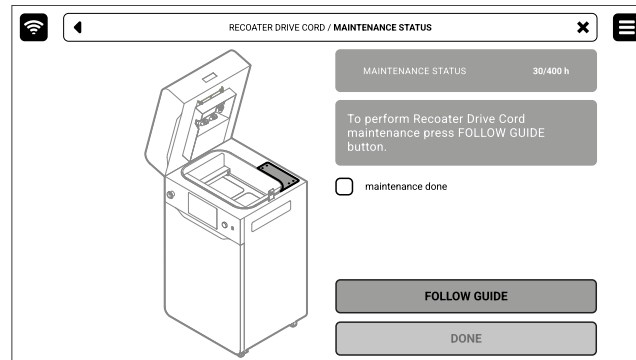

Fig. 12.61 The screen of the maintenance of the Recoater Drive Unit Cord.

4. Choose **UNLOCK LID** on the screen.
5. Push on the lid and pull it up using the lid handle. Remember, you only have 10 seconds to open it before the lock activates again.
6. Using a 2 mm allen key remove the four screws securing the access panel on the top side of the printer (fig. 12.62).
7. Remove the access panel on the top side of the printer (fig. 12.63).

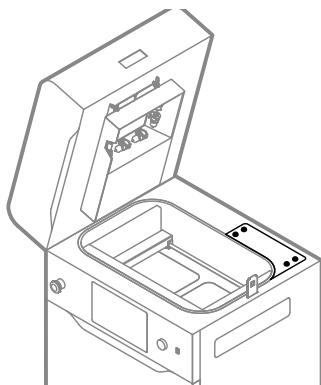

Fig. 12.62 Remove four screws from the access panel.

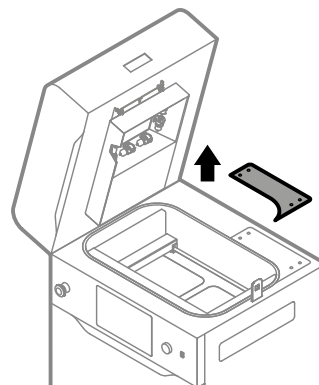

Fig. 12.63 Remove the access panel.

8. Now you have access to the tightening mechanism.
9. To tighten the cord, use a 7 mm wrench and loosen the three screws marked in figure 12.64.
10. Screw the marked bolt with a torque wrench (fig. 12.65). Tighten the cord for a value of 21 Ncm.

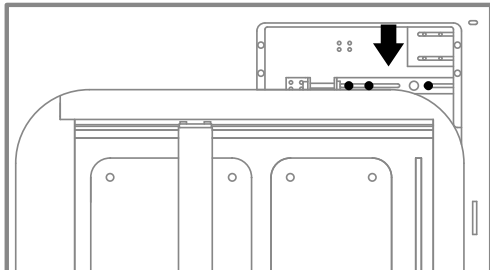

Fig. 12.64 Loose the three screws of the tighten mechanism.

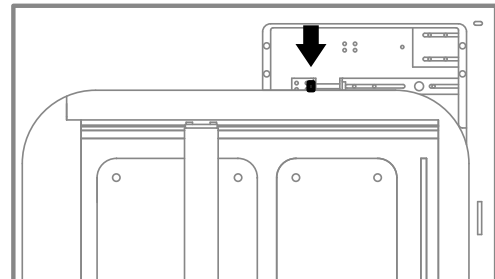

Fig. 12.65 Screw the marked bolt with a torque wrench.

11. Using a 7 mm wrench, tighten back the three screws marked in figure 12.64.
12. Mount back the access panel on the top side of the printer (fig. 12.66).
13. Using a 2 mm allen key, tighten back the four screws securing the access panel on the top of the printer (fig. 12.67).
14. Good job. The maintenance timer will reset to zero.

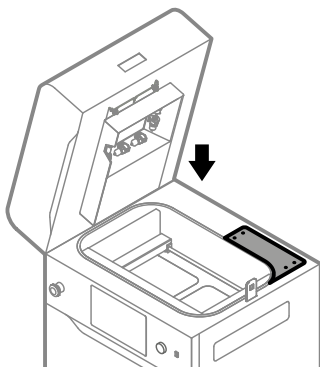

Fig. 12.66. Mount back the access panel.

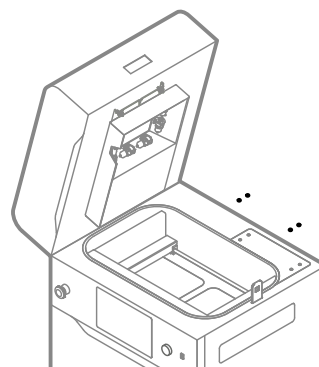

Fig. 12.67 Tighten back four screws of the access panel.

12.12 CHECKING THE TENSION OF THE RECOATER DRIVE UNIT CORD. (REV. C)

You will need: 2 mm allen key, 2.5 mm allen key, 7 mm wrench, 10 mm torque wrench

Every approx. 400 hours is required to check the tension of the Recoater Drive Unit Cord. A properly tensioned cable is springy, with no curve, and under finger pressure, it flexes by about 0,5 cm.

1. On the **PRINTER STATUS** tab, select the **RECOATER DRIVE CORD** position.
2. The maintenance tab of the checking Recoater Drive Unit Cord will appear on the screen. You can use the step-by-step guide (press **FOLLOW GUIDE**) or perform the replacement yourself.
3. In this case, mark **MAINTENANCE DONE** once you have completed the procedure, and then the **DONE** button. The timer will reset to zero (fig. 12.68).

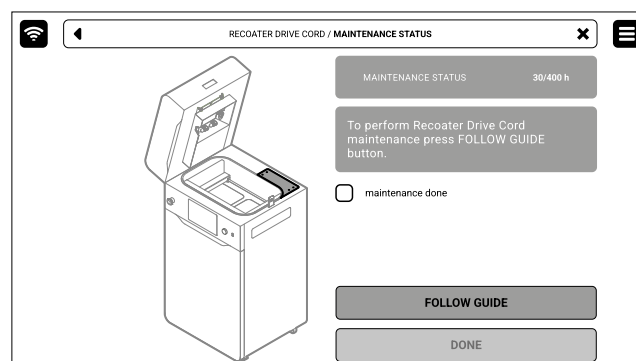

Fig. 12.68 The screen of the maintenance of the Recoater Drive Unit Cord.



4. Choose **UNLOCK LID** on the screen.
5. Push on the lid and pull it up using the lid handle. Remember, you only have 10 seconds to open it before the lock activates again.
6. Using a 2.5 allen key, remove the six screws securing the access panel on the right side of the printer (fig. 12.69).
7. Remove the access panel on the right side of the printer (fig. 12.70).

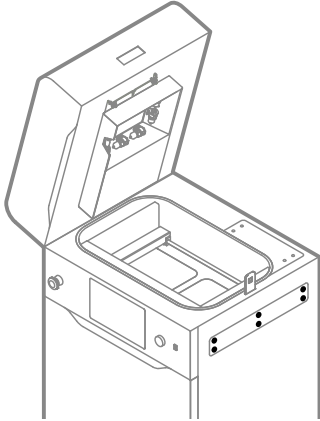

Fig. 12.69 Remove six screws from the access panel.

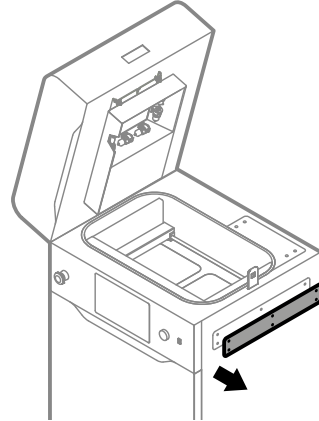

Fig. 12.70 Remove the access panel.

8. Using a 2 mm allen key remove the four screws securing the access panel on the top side of the printer (fig. 12.71).
9. Remove the access panel on the top side of the printer (fig. 12.72).

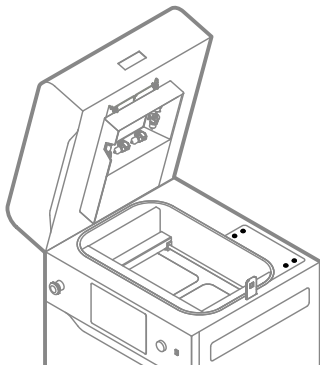

Fig. 12.71 Remove four screws from the access panel.

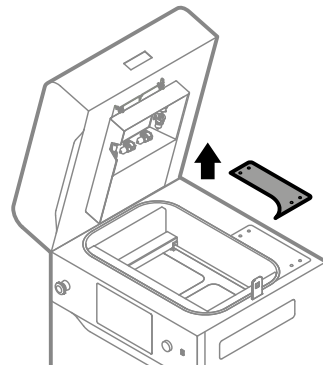

Fig. 12.72 Remove the access panel.

10. Now you have access to the tightening mechanism.
11. To tighten the cord, use a 7 mm wrench and loosen the three screws marked in figure 12.73.
12. Through the inspection opening on the right side of the printer tighten the bolt marked with a torque wrench (fig. 12.74). Tighten the cord for a value of 10 Ncm.

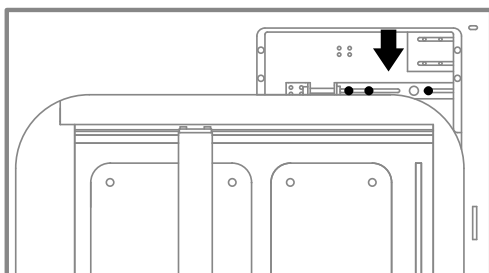

Fig. 12.73 Loose the three screws of the tightening mechanism.

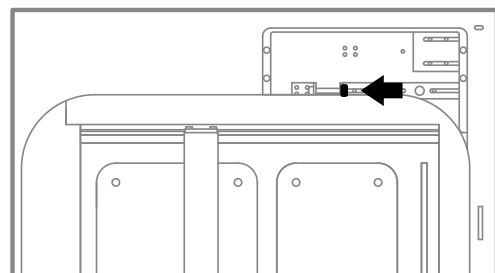

Fig. 12.74 Screw the marked bolt with a torque wrench.

13. Using a 7 mm wrench, tighten back the three screws marked in figure 12.73.
14. Mount back the access panel on the top side of the printer (fig. 12.75).



15. Using a 2 mm allen key, tighten back the four screws securing the access panel on the top of the printer (fig. 12.76).

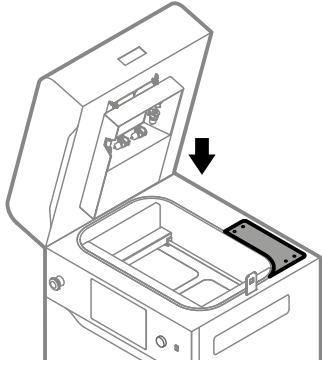

Fig. 12.75 Mount back the access panel

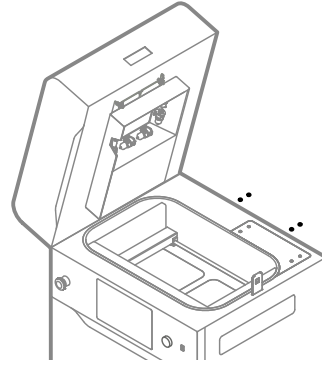

Fig. 12.76 Tighten back four screws of the access panel.

16. Mount back the access panel on the right side of the printer (fig. 12.77).

17. Using a 2.5 mm allen key, tighten back the six screws securing the access panel on the right side of the printer (fig. 12.78).

18. Good job. The maintenance timer will reset to zero.

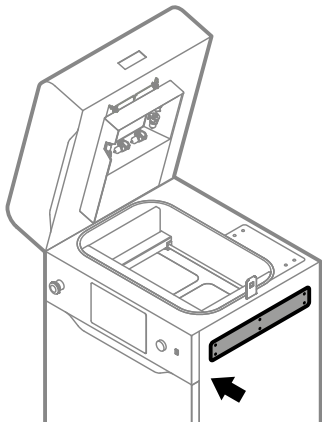

Fig. 12.77 Mount back the access panel.

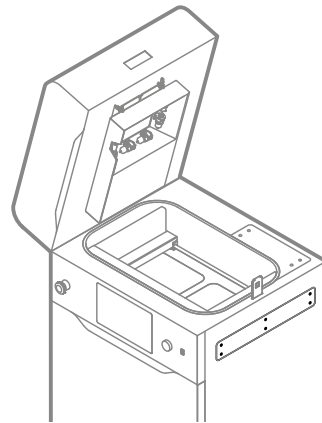

Fig. 12.78 Tighten back six screws of the access panel.

12.13 CLEANING THE INNER REAR TRAY

During printing, a certain amount of powder may accumulate on the inner rear protective tray. In order to keep the printer in good condition, we recommend checking the amount of powder on it no less than weekly and vacuuming it with the ATEX Vacuum Cleaner if necessary.

12.14 SPARE PARTS FOR LISA X

List of spare parts:

- Laser protective glass with foam sealing
- Reflector foam sealing
- Pyrometer window module
- Print Bed sealing
- Feed Bed sealing
- Recoater drive unit cord
- Recoater cord (short)
- Recoater slider
- Drive Belt GT2
- Infrared bulb
- **Supply kit** – the basic set of spare parts supplied with the printer. Includes Recoater Short Cords and Infrared bulbs.
- **Consumables kit** – Extended spare parts kit, extra charge.



13. Expert Mode

This mode makes it possible to disable the printer's security features and shorten processes, including but not limited to skipping prepress steps and disabling security mechanisms, allowing direct use of manual control of recoaters and bed positions, in particular when the Safety System is disabled.

As there are serious risks associated with the use of this mode, please acknowledge yourself and follow the safety rules below.

If there is any other person besides you using the printer, pay special attention to the section "MULTI-USERS".

13.1 IMPORTANT SAFETY INFORMATION

	<p>WARNING!</p> <ul style="list-style-type: none"> Expert Mode involves the possibility of bypassing the printer's security features. <u>The Expert Mode is intended only for people with extensive experience in working with the Sinterit printer!</u> Incompetent use of this mode can be a direct cause of accidents. Risks include the possibility of mechanical crushing, tearing and severe burns leading to personal injuries including even fatal accidents. 	
	<p>WARNING!</p> <ul style="list-style-type: none"> While using this mode, pay the utmost attention to the Sinterit printer and its working process. <u>Do not put any body parts including but not limited to limbs, or any elements, appliance parts, etc. into the movement zone of mechanical parts!</u> 	
	<p>WARNING!</p> <ul style="list-style-type: none"> <u>Do not force open the chamber before the cooling process is completed!</u> In the case of early completion of the printout by skipping the cooling stage, please take into account that the printout has a temperature of about 150 [°C] / about 300 [°F]. Processing prints before they have cooled is very dangerous. 	
	<p>WARNING!</p> <ul style="list-style-type: none"> By activating Expert Mode, you unequivocally confirm that you accept all of the risks involved and that your decision to disable the printer's safety features is fully informed and conscious. <u>Use of the Expert Mode is solely at your own risk.</u> 	

13.2 ENABLING „EXPERT MODE“

	<p>IMPORTANT!</p> <ul style="list-style-type: none"> Expert Mode is available only to Sinterit Studio Advanced users. To run the mode, first read the security rules. Make sure that the printer has the latest available software version.
--	---

1. Select **SETTINGS** from the main menu and press MORE OPTIONS.
2. Find and press the **EXPERT MODE** tab.
3. Move the slider to the right to activate the mode **OFF** → **ON** (Fig. 13.1).
4. Read carefully and confirm the safety rules - it's important! (Fig. 13.2)



Fig. 13.1 Expert Mode tab.

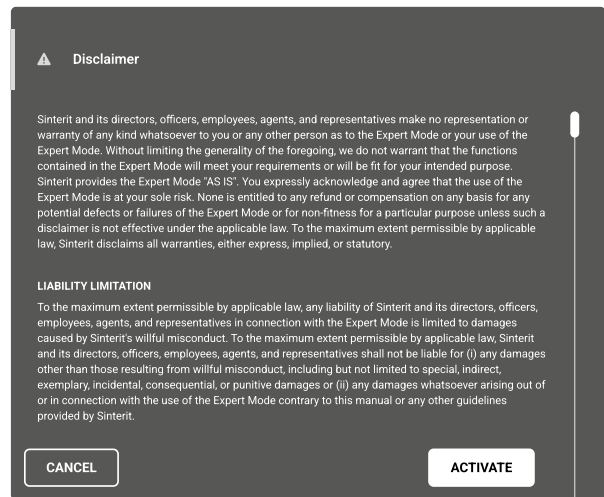

Fig. 13.2 Read and confirm the safety rules.

5. Enter the activation code on the screen and click to confirm (Fig. 13.3). Enter the activation key: 746837.
6. Activation of the code will be confirmed by lighting up the yellow icon with the letter E in the upper left corner. Until deactivated, the Expert Mode remains active and the icon is on (Fig. 13.4).



Fig. 13.3 Enter code and confirm.

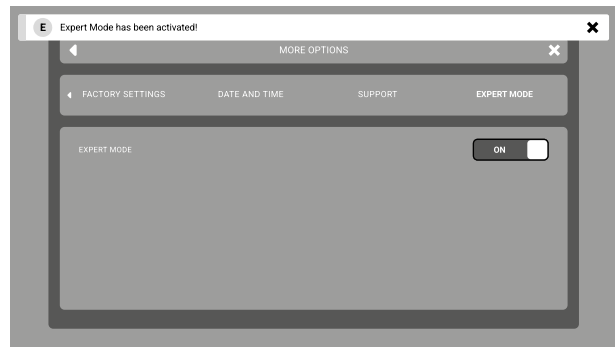



Fig. 13.4 Screen confirming Expert Mode enabled.

13.3 MULTI-USERS



ATTENTION!

For multi-user operation, the following rules must be met:

- each person using the printer, no matter if they work with the Expert Mode or not, must be acknowledged with this manual before any use of the printer;
- each user should start working with the printer by checking whether the Expert Mode is disabled;
- only a user who personally activated the Expert Mode, may use it;
- a user who activated the Expert Mode is responsible for deactivating it immediately after finishing work with the printer.

13.4 DEACTIVATION OF THE EXPERT MODE

1. Select **SETTINGS** from the main menu and press **MORE OPTIONS**.
2. Find and press the **EXPERT MODE** tab.
3. Move the slider to the left to deactivate the mode (**ON → OFF**).
4. To confirm whether deactivation has been completed please see if the Expert Mode icon in the upper left corner has disappeared and check the **SETTINGS** (Fig. 13.5).

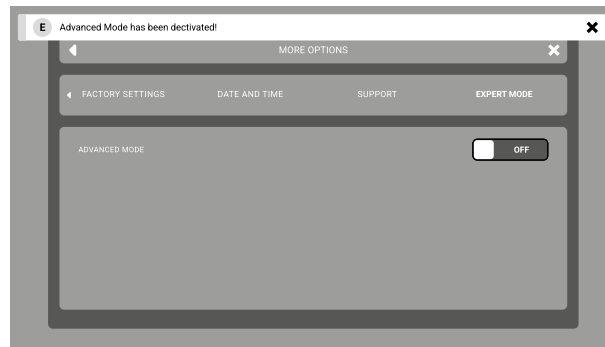

Fig.13.5 Screen confirming Expert Mode is disabled.

13.5 OPTIONS TO WORK IN EXPERT MODE

13.5.1 Control Panel

- In Expert Mode, a control panel for the Beds position and Recoater position is provided. Control is done manually by using the sliders on the screen.
- This mode allows convenient control during service operations such as replacement of components or cleaning.
- Remember safety rules when using this panel.

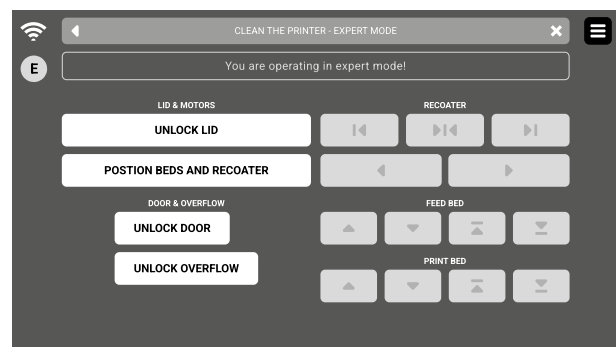

Fig. 13.6 Control panel in the Expert Mode.

13.5.2 No Wizard

- When Expert Mode is activated there is no wizard on launching the printing process.
- There are no standard user guides.
- To speed up the process, all necessary functions for each printing stage are collected in specific submenus.
- All steps are manually controlled.

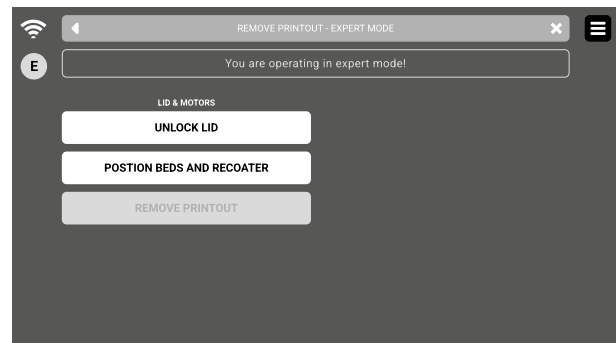











Fig. 13.7 Self-directed work in Expert Mode.

13.5.3 Skip Self-check

Expert Mode allows you to skip self-checks, which shortens the time of preparation for printing. Skipping this step exposes you to a greater chance of printing failure and should be done only when you are sure that heating elements, cord and other printer components are in perfect condition and their condition allows for successful printing.

13.5.4 Hot printouts

	<p>WARNING!</p> <ul style="list-style-type: none">• For safety reasons, we always recommend you to not process prints until they have cooled and reached a temperature of 50 [°C] / about 120 [°F] (when the built-in safety mechanism will allow you to open the cover).• Slow cooling is an essential printing process and its interruption can lead to deformation of prints.	 
	<p>WARNING!</p> <ul style="list-style-type: none">• The Expert Mode allows you to open the lid and eject the cake regardless of the temperature.• This means that the print temperature can be as high as 150 [°C] / about 300 [°F].• <u>If you decide to process a hot print, you do it at your own risk!</u>	 
	<p>WARNING!</p> <ul style="list-style-type: none">• Remember that the IO Box has no insulation and special protective gloves as well as protective clothing should be used.• Prints and powder can keep the temperature inside the cake high for many hours.• Using such a hot print for PHS or other processing can lead to life-threatening burns.	 

13.6 EXPERT MODE – DISCLAIMER

Sinterit and its directors, officers, employees, agents and representatives make no representation or warranty of any kind whatsoever to you or any other person as to the Expert Mode or your use of the Expert Mode.

Without limiting the generality of the foregoing we do not warrant that the functions contained in the Expert Mode will meet your requirements or will be fit for your intended purpose.

Sinterit provides the Expert Mode “as is”.

You expressly acknowledge and agree that use of the Expert Mode is at your sole risk.

None is entitled to any refund or compensation on any basis for any potential defects or failures of the Expert Mode (as well as defects or failures of printers or print-outs arising during or in connection with the use of Expert Mode) or for non-fitness for a particular purpose, unless such a disclaimer is not effective under the applicable law (in such a case, a not effective part of the disclaimer shall be replaced by the mandatory provisions of law and the remaining part shall stay in force).

To the maximum extent permissible by applicable law Sinterit disclaims all warranties, either express, implied, or statutory.

13.7 EXPERT MODE – LIABILITY LIMITATION

To the maximum extent permissible by applicable law any liability of Sinterit and its directors, officers, employees, agents and representatives in connection with the Expert Mode is limited to damages caused by Sinterit willful misconduct. To the maximum extent permissible by applicable law Sinterit and its directors, officers, employees, agents and representatives shall not be liable for (i) any damages other than resulting from willful misconduct, including but not limited to special, indirect, exemplary, incidental, consequential or punitive damages or (ii) any damages whatsoever arising out of or in connection with the use of the Expert Mode contrary to this manual or contrary to any other guidelines provided by Sinterit. To the maximum extent permissible by applicable law liability of Sinterit and its directors, officers, employees, agents and representatives shall not include, without limitation: (i) personal injury, (ii) damage or malfunction to printers or printouts, (iii) damage to property.



14. Industry 4.0

Get Printer Info to obtain information about the printer, make to HTTP Request.

GET <printer-ip>:2222/info
insert your printer ip address

Example request:

```
{
  „data“: {
    „status“: {
      „PrintProgress“: 1,
      „EstimatedTimeLeftS“: 0,
      „IsPrintInProgress“: false,
      „LayerCount“: 2579,
      „CurrentLayer“: 2579,
      „StatusMessage“: „FINISHED“,
      „CurrentSCodeFilename“: „yourScodeName.scode“,
      „IsPrintoutReadyToRemove“: true,
      „PrintSurfaceTemperature“: 27.902999877929688,
      „PrintInterruptionReason“: „none“,
      „WarmupProgress“: 1,
      „EstimatedWarmupTimeLeftS“: 0,
      „PrintingStageProgress“: 1,
      „EstimatedPrintingStageTimeLeftS“: 0,
      „CooldownProgress“: 1,
      „EstimatedCooldownTimeLeftS“: 0
    },
    „wifi_status“: {
      „ssid“: „wifiName“,
      „state“: „COMPLETED“,
      „signal“: -54,
      „ResultOK“: true
    },
    „errors“: [
      {
        „id“: 1074790757,
        „code“: 357,
        „is_critical“: true,
        „raise_time“: „2023-01-01T00:00:00“,
        „description“: „FeedBed lost steps detected“
      }
    ],
    „printer_serial_number“: „0000000000“,
    „software_version“: 522,
    „last_printout_start_time“: „2023-01-01T00:00:00“,
    „last_printout_finish_time“: „2023-01-01T00:00:00“,
    „estimated_printout_finish_time“: „2023-01-01T00:00:00“
  }
}
```



Response info

- **PrintProgress** -The progress of the whole print (float in the range of 0-1);
- **EstimatedTimeLeftS** - estimated print time (all including warmup and cool down);
- **IsPrintInProgress** - value true/false;
- **LayerCount** - number of printout layers
- **CurrentLayer** - current layer
- **StatusMessage** - statuses: „STARTING“, „WARMING UP“, „PRINTING“, „COOLING DOWN“, „READY“, „Not printing“
- **CurrentSCodeFilename** - name of the currently printed file;
- **IsPrintoutReadyToRemove** - value true/false;
- **PrintSurfaceTemperature** - print temperature in Celsius degrees °C
- **PrintInterruptionReason** - in the case of a critical error, supplemented with an error
- **WarmupProgress** - the progress for warmup (float in the range of 0-1);
- **EstimatedWarmupTimeLeftS** - estimated warm-up time left;
- **PrintingStageProgress** - the progress for just laser printing (float in the range of 0-1);
- **EstimatedPrintingStageTimeLeftS** - estimated time of the current printing phase ;
- **CooldownProgress** - the progress for cooldown (float in the range of 0-1)
- **EstimatedCooldownTimeLeftS**- estimated cooldown time;
- **wifi_status** - info about wifi (name, signal strength)
- **errors** - table with errors (empty if there are no errors)
- **printer_serial_number** - serial number of the machine
- **software_version** - current software version
- **Last_printout_start_time** - last printout start time
- **Last_printout_finish_time** - last printout finish time
- **Estimated_printout_finish_time** - estimated printing finish time

Score upload

Upload single files with FormData HTTP Request

POST <printer-ip>:2222/uploadFile
insert your printer ip

formData key value example:

key	value
scode	yourScore.scode

Response info:

- **success** - value true/false (scode uploaded);
- **response errors**

Potential response title error values:

- **Only score files are allowed** - you are trying to send an improper file.
- **Not enough free space, try to remove old score first** - not enough space on printer disk



REMEMBER!

Send only files generated in Sinterit Studio.



15. Technical support

If you have any questions or doubts, please contact our after-sales department.

e-mail: support@sinterit.com

phone: +48 570 702 886

For a list of distributors and technical support in each country, please visit our website www.sinterit.com

16. Packing the machine for shipping

16.1 PREPARING THE PRINTER

1. From the main menu, select **CLEAN THE PRINTER** and follow the directions. For a more detailed description, see Chapter 9. *Cleaning the printer*.
2. Remove the split pin and lower the heating module.
3. Unscrew two quick release nuts.
4. Take the laser protective glass out and put it in its original box.
5. Lift the heating module and secure it with a split pin.
6. Insert the box with the laser protective glass into the print chamber.
7. Close the printer lid.
8. Disconnect the power cable from the printer.

16.2 PACKING THE PRINTER INTO THE FLIGHT CASE

1. Unlock the latches on the case door (4 pcs.). Lift the lock handle up to a perpendicular position, then turn it clockwise.
2. Take the flight case cover off.
3. Lift the gangway support and lower the gangway.
4. Slide the printer into the flight case. This step requires the help of another person.



ATTENTION!

Start packing the printer from the lid hinges side.

5. Attach the power cable to the flight case cover.
6. Fold the gangway and attach the flight case cover.
7. Lock the flight case lid latches.
8. Secure the flight case with foil and tape.



17. General legal information

Where this manual refers to Sinterit or the Company or “us/our”, this means Sinterit sp. z o.o. with its legal seat in Krakow, registered by the District Court for Kraków-Śródmieście in Krakow, XI Commercial Division of the National Court Register under number: 535095, NIP (tax number): 6793106416, with the share capital for date of publication of this manual of PLN 106,600 (say: one hundred six thousand and six hundred).

This document contains material protected under copyright and industrial property laws. In particular, this means that the document may not be reproduced or modified without the consent of Sinterit.

This manual serves to assist you in the correct use of the device, perform basic maintenance, and, if necessary, solve simple problems, allowing you to maintain the device in good condition.

This manual contains content exclusively for the provision of information and for use by individuals who have been professionally trained in the operation and maintenance of the equipment described below.

The information contained in this document is intended for use only with the product made by Sinterit and called Sinterit Lisa X.

Due to the constant development of Sinterit products the information contained in this manual as well as any specifications and markings issued or placed on Sinterit products by the Company are subject to change without notice.

18. Disclaimer

Sinterit is not responsible for any use of this information about other products.

Although every effort has been taken to provide accurate information about the product, Sinterit disclaims, to the widest extent permitted under the applicable law, any and all liability for any incorrect information or omission, and for anything that may result from such errors or omissions. Sinterit reserves the right to correct any and all errors and omissions at any time.

Further limitations or exclusions of Sinterit liability may result from the applicable laws or agreements entered into with the buyer of the products.

19. Trademarks

The Sinterit logo is a registered trademark of the Company.



20. Warranty information

Terms of warranty granted by Sinterit are outlined in the agreement between Sinterit and the person or entity that buys our product/s directly from us. It means that:

- if you are a Sinterit distributor, terms of warranty result from the distribution agreement between us,
- if you bought our product/s in our online shop, terms of warranty result from the Terms and Conditions being in force on the date of your sale,
- if you are not our distributor and bought our products directly from us but outside our online shop, the warranty terms may be specified in the Terms and Conditions linked in the offer, or in another document provided to you by Sinterit.

If you bought our products from a third party, e.g. our distributor, you should ask the seller about the warranty.

Unless otherwise stated in the documents referred to above or specifically agreed to by us, the warranty does not cover, without limitation:

- damages, abnormalities or malfunction caused by a customer or any third party;
- damages, abnormalities or malfunction caused by inappropriate use, effects of force, insufficient or inappropriate maintenance, abnormal operating conditions, incorrect installation or inadequate servicing;
- damages, abnormalities or malfunction caused by dismantling, alterations, tuning or other changes of the product by a customer or any third party made without the written consent of Sinterit;
- damages, abnormalities or malfunction caused by or related to the use of consumables other than those being supplied by Sinterit, or the use of consumables in a non-standard or not recommended way;
- damages, abnormalities or malfunction caused by or related to the use of the product against its intended use, instructions/ manuals or safety regulations;
- costs of any cleaning of working parts;
- damages, abnormalities or malfunctions Sinterit is not liable for, according to the applicable law,
- costs incurred by the customer in connection with the conclusion of the product sale agreement as well as storage or insurance of products;
- damages of property caused by the defect of the product;
- loss of profits;
- incidental, indirect, special, consequential or punitive damages.

Please also be aware that material properties of any print-out may depend on part design and manufacturing methods. You are responsible to check the usability and fitness of the print-out for the intended purpose.

Sinterit shall neither be liable for any damage caused by any malfunction of the printed part nor for any of them being unfit for the specific use or purpose.

Under no circumstance may the liability of Sinterit exceed the price paid for Lisa X.

Any and all warranties other than explicitly granted by Sinterit, including but not limited to that of merchantability or fitness for intended purpose are specifically disclaimed.

The abovementioned exclusions of warranty also apply to any other liability of Sinterit (no matter if based on contract, tort or any other legal theory), to the widest extent permitted by the applicable law.

21. Technical support

If you have any questions or doubts, please contact our after-sales department.

- e-mail: support@sinterit.com
- phone: +48 570 702 886

For a list of distributors and technical support in each country, please visit our website www.sinterit.com



22. Residual risk

Even when the product is used as intended and prescribed, it is still impossible to eliminate certain residual risk factors. The following hazards may arise in use and the operator should pay special attention or use additional equipment to avoid the following:

1. Exposure to loss of stability and product overturning may cause bludgeoning or crushing, pay attention when transporting, installing, operating, or maintaining the product.
2. Exposure to electric shock may cause severe health injuries (in case of connecting the power supply to a socket without an appropriate connection for the protective grounding) - use only a dedicated connection cable, provided by the manufacturer.
3. Exposure to electric shock can cause serious damage to your health. Never use the machine with guards removed or with a safety system that is not working properly.
4. Exposure to sharp edges may cause cuts - wear protection gloves.
5. Exposure to powders may cause discomfort, health impairment and/or skin irritations - read the powder safety data sheet, wear protective gear and/or limit exposure.
6. Inhalation of powders may cause respiratory irritation - read the safety data sheet, wear a protection mask and/or limit exposure.
7. The machine is equipped with a laser that can cause permanent harm to health. Never use the machine with removed guards or with a safety system that is not working properly.

**The manufacturer is not responsible for any internal and/or external defect of the power supply used by the user if it does not come directly from the manufacturer or designated party.*



23. Centre of gravity of the Lisa X device

23.1 DEVICE WITH CLOSING LID

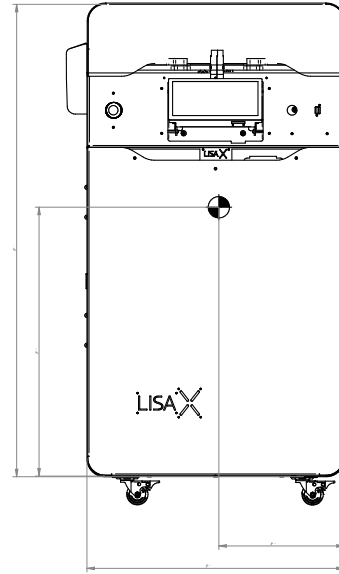
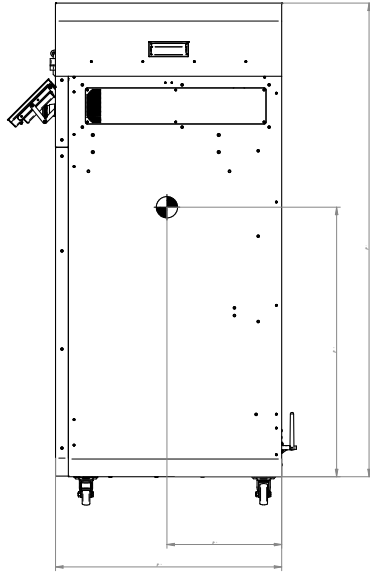

		Sinterit sp. z o.o. ul. Nad Drwiną 10 30-741 Kraków			
Konstruował:	Nazwisko	Data	Materiał	Working	
Sprawdził:	Ernest Kowalski	29.01.2021	Masa	003846	
Zatwierdził:			NADZWI	003846	
			1:5	A1	A

23.2 DEVICE WITH OPEN LID

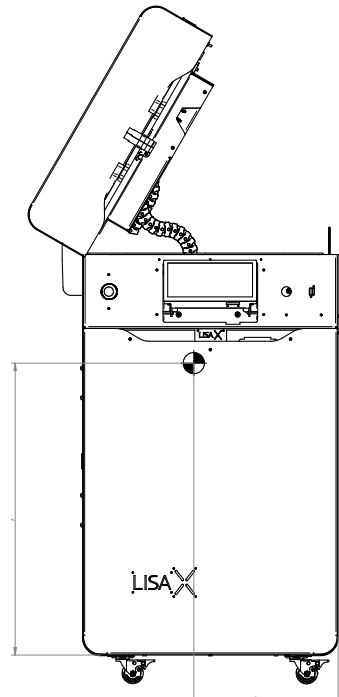
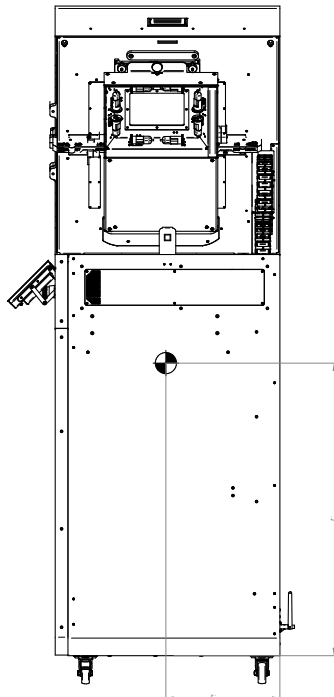

		Sinterit sp. z o.o. ul. Nad Drwiną 10 30-741 Kraków			
Konstruował:	Nazwisko	Data	Materiał	Working	
Sprawdził:	Ernest Kowalski	29.01.2021	Masa	003846	
Zatwierdził:			NADZWI	003846	
			1:5	A1	A



24. EC/EU Declaration of Conformity

within the meaning of:

DIRECTIVE 2014/35/EU OF THE EUROPEAN PARLIAMENT AND OF THE COUNCIL of 26 February 2014 – Annex IV
DIRECTIVE 2014/30/EU OF THE EUROPEAN PARLIAMENT AND OF THE COUNCIL of 26 February 2014 – Annex IV
DIRECTIVE 2011/65/EU OF THE EUROPEAN PARLIAMENT AND OF THE COUNCIL of 08 June 2011 – Annex VI
DIRECTIVE 2006/42/EC OF THE EUROPEAN PARLIAMENT AND OF THE COUNCIL of 17 May 2006 – Annex II 1.A

Business name and full address of manufacturer:	Given name and surname of the person authorised to compile and to deliver the technical file:	
 SINTERIT Sinterit spółka z o.o. ul. Nad Drwiną 10/B-3 30-741 Kraków POLAND	Michał Grzymała-Moszczyński Sinterit spółka z o.o. ul. Nad Drwiną 10/B-3 30-741 Kraków POLAND	
We declare that the machine:		
Name:	Lisa X	
Type:	Lisa X rev. B-F	
Serial number:	031xxxxxxxx where X is a digit from 0 to 9	
meets all the relevant provisions of the following Community Directives:		
DIRECTIVE 2014/35/EU OF THE EUROPEAN PARLIAMENT AND OF THE COUNCIL of 26 February 2014 (LVD)		
DIRECTIVE 2014/30/EU OF THE EUROPEAN PARLIAMENT AND OF THE COUNCIL of 26 February 2014 (EMC)		
DIRECTIVE 2011/65/EU OF THE EUROPEAN PARLIAMENT AND OF THE COUNCIL of 8 June 2011 (ROHS)		
DIRECTIVE 2006/42/EC OF THE EUROPEAN PARLIAMENT AND OF THE COUNCIL of 17 May 2006 (MD)		
and the requirements of the following harmonised standards:		
PN-EN ISO 12100:2012	Safety of machinery -- General principles for design -- Risk assessment and risk reduction	
PN-EN ISO 13857:2020-03	Safety of machinery -- Safety distances to prevent hazard zones being reached by upper and lower limbs	
PN-EN ISO 13850:2016-03	Safety of machinery -- Emergency stop function -- Principles for design	
PN-EN ISO 13849-1:2016-02	Safety of machinery -- Safety-related parts of control systems -- Part 1: General principles for design	
PN-EN ISO 13849-2:2013-04	Safety of machinery -- Safety-related parts of control systems -- Part 2: Validation	
PN-EN 60204-1:2018-12	Safety of machinery -- Electrical equipment of machines -- Part 1: Specification for general requirements	
Other		
<p>This declaration relates exclusively to the machine in the state in which it was placed on the market, and excludes components added and/or operations carried out subsequently by the final user. This declaration of conformity is issued under the sole responsibility of the manufacturer. The subject matter of the declaration referred to above is in conformity with the relevant EU harmonisation legislation. The subject matter of the declaration described above complies with Directive 2011/65/EU of the European Parliament and of the Council of 8 June 2011 on the restriction of the use of certain hazardous substances in electrical and electronic equipment (OJ L 174, 1.7.2011, p. 88.).</p>		
Krakow, 23.05.2022	 Maxime Polesello President of the Management Board	 Michał Grzymała-Moszczyński Member of the Management Board
Place and date (of issue) of the declaration	Given name, surname, title, signature of the manufacturer or of an authorised person	

Sinterit spółka z ograniczoną odpowiedzialnością, ul. Nad Drwiną 10 bud. B3, 30-741 Kraków, entered in the register of entrepreneurs kept by the District Court for Kraków-Śródmieście, 11th Commercial Department of the National Court Register under the number KRS 535095, tax identification number NIP 6793106416 and statistical no. REGON 360309767, share capital: PLN 102,200 (one hundred and two thousand, two hundred zlotys).

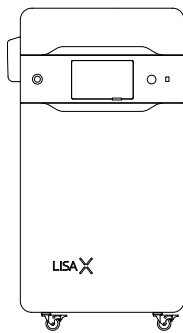

SINTERIT Sp. z o.o.
ul. Nad Drwina 10/B-3, 30-741 Krakow, Poland
www.sinterit.com