

LISA X

SLS 3D printer

Translation of the original short manual



Please read the user manual before using the product.





Table of contents



- 1. Printer overview4
- 2. Preparing to print.....5
 - 2.1 Starting the printer 5
 - 2.2 Choosing the file to print..... 6
 - 2.3 Filling the printer with powder 6
 - 2.4 Preparing the print chamber 7
 - 2.5 Final steps before printing 7
- 3. Removing and cleaning the printout.....8
- 4. Cleaning the printer9
- 5. Technical support10

The short manual provides only a basic overview of the device and its general use. It will guide you throughout the entire printing process. To learn more about specific features of your printer and read the latest version of the user manuals, please visit our website www.sinterit.com/support-page/. Sinterit disclaims any liability resulting from the lack of knowledge provided in the full manual.

Listed below are the conventional symbols used throughout the guide and basic safety rules for working with the machine. They indicate warnings or carry important notices, so as to protect the user, any bystanders and objects in the vicinity. They also provide the basic guidelines for proper and safe operation of the device.

	<p>WARNING!</p> <p>An inevitably dangerous situation which can result in serious injury or even death. Initiation, or omission, of a specific procedure as well as inattention, can cause severe physical injury to the user.</p>
	<p>ATTENTION!</p> <p>Initiation, or omission, of a specific procedure can cause physical damage to the equipment or the user.</p>
	<p>DANGER!</p> <p>Risk of electric shock. An inevitably dangerous situation, potentially resulting in severe burns or even death. Before operating any electric device, it is important to understand the dangers of electricity and the proper procedures to mitigate them, as well as the steps necessary to perform in case of a related emergency.</p>
 	<p>WARNING!</p> <p>Compressed gas! Danger of suffocation!</p> <p>Possibility of unsealing - gas has a suffocating effect on people by displacing oxygen from the air. Too low oxygen concentration in the air can lead to unconsciousness and death, if not mitigated. Inhalation exposure may cause short breath, breathing difficulties, headaches and dizziness, with high concentrations of gas disorders of orientation, nausea, fainting, loss of consciousness, death.</p>
	<p>ATTENTION!</p> <p>IR laser radiation. Looking directly into the laser beam can cause blindness and skin burns. The laser emits infrared radiation (infrared, IR), which is invisible to humans. Avoid eye or skin exposure to direct or scattered radiation. Do not stare into the beam or view with optical instruments.</p>
	<p>ATTENTION!</p> <p>High temperature – do not touch. Excess heat dissipation can cause burns.</p>



	ATTENTION! Beware of moving parts which can crush hands.
	ATTENTION! Beware of sharp edges which can cause body cuts and injury.
	ATTENTION! Beware of intense light.
 	DANGER! Risk of fire and explosion! Avoid fire! Powder dust is flammable.
	ATTENTION! Risk of electric shock. A grounding is used in the printer. Follow the instructions in the User manual and the markings on the printer.
	STOP! Action is strictly prohibited.
  	ATTENTION! It is necessary to wear adequate protective clothing, eyewear, face mask, and gloves. Mandatory action when working with powder.
	ATTENTION! It is recommended to wear antistatic clothing and shoes. The floor in the working area must be antistatic.
	IMPORTANT! Information essential to correctly perform a specific task. Information essential to correctly perform a specific task.
	IMPORTANT! Be sure to read the instructions in this user manual carefully.



1. Printer overview

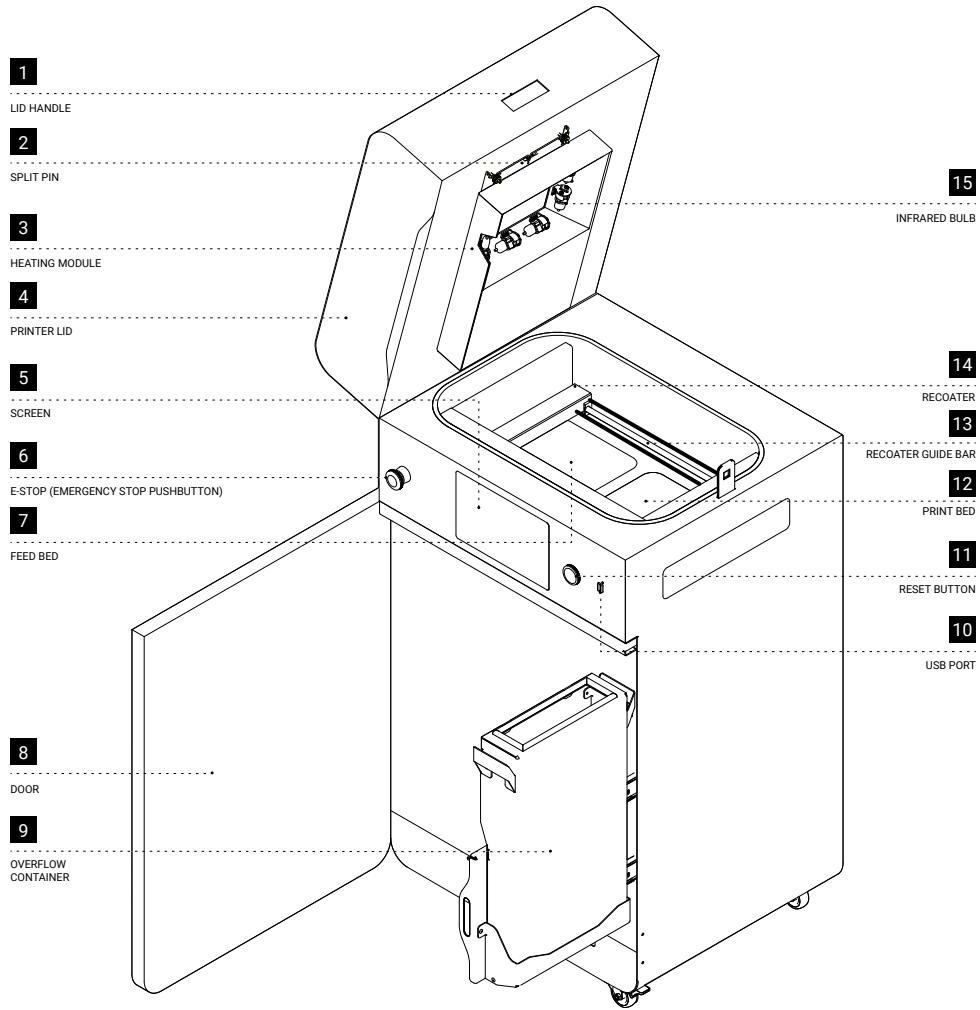

Fig. 1.1 View of the front of the printer, heating module, print chamber, and overflow container.

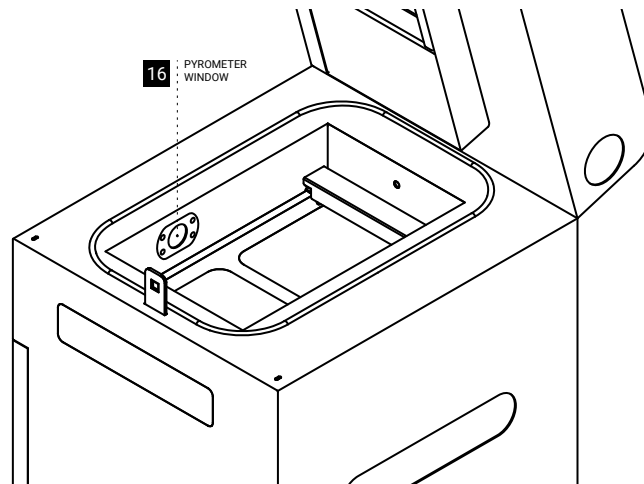
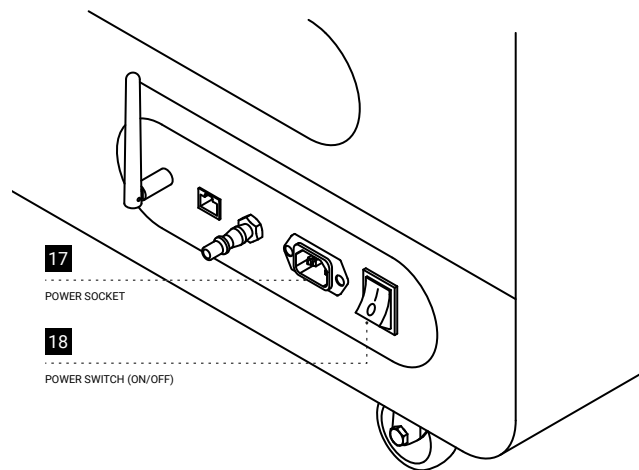

Fig. 1.2 View of the pyrometer window.



1.3 View of the back of the printer.

2. Preparing to print

2.1 Starting the printer

1. Connect the printer to a power source (fig. 2.1). Power socket is located on the back of the printer.
2. Flip the power button on the back of the printer to the I position.

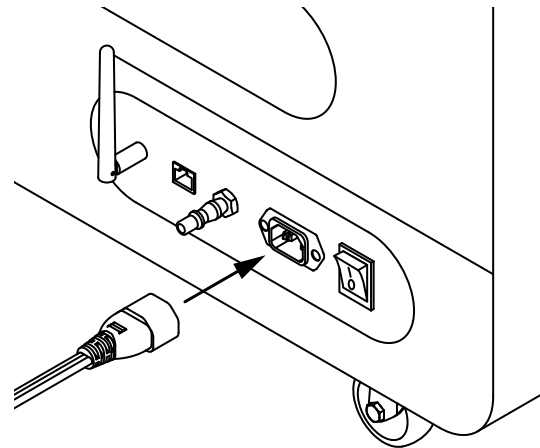

Fig. 2.1 Connecting the power cord to the power socket.

3. Make sure that the **E-STOP** button is released. If not, turn it clockwise as much as possible and release it. (fig. 2.2).

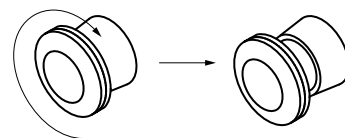

Fig. 2.2 Releasing the E-STOP button.

4. After a few seconds, the main menu should appear on the printer screen.



ATTENTION!

While preparing the printer for use, it is necessary to read and acknowledge any messages on the screen. Disregarding or skipping any crucial steps of the process can negatively impact the quality of printouts or damage the printer.



2.2 Choosing the file to print



IMPORTANT!

In order to print, you will need a file prepared in Sinterit Studio, which you can download from our website www.sinterit.com/software.

1. Select ► **PRINTING** from the main menu and press ⊕ **ADD NEW PRINT JOB**.
2. Choose the new file (**USB**) or recently used file (**RECENT**).
3. The following screen displays some basic information about the processed file (**PRINT JOB**) as well as the current status of the printer (**PRINTER STATUS**). Press ► next to the component timer for more information. If at this point you want to choose another file to print, press **CHANGE PRINT JOB**. Press **DONE**.



IMPORTANT!

If any part of the printer requires maintenance or replacement, a corresponding message will appear on the screen.

2.3 Filling the printer with powder

1. Press **UNLOCK LID** to release the electrolock and allow the print chamber to be opened.



IMPORTANT!

After 10 seconds the electrolock will activate and it will no longer be possible to lift the lid. If you still want to open the printer, press the **UNLOCK LID** button again on the printer screen.

2. Push on the lid and pull it up using the lid handle (fig. 2.3).

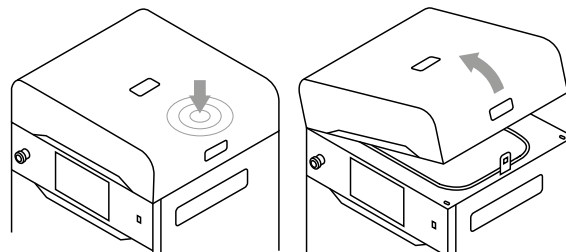

Fig. 2.3 Lifting the printer lid.

3. Make sure the print chamber is free of any unwanted items that may interfere with moving recoater.
4. Press **POSITION BEDS** to begin the positioning process of the Beds.
5. Once the positioning process is finished, fill the Feed Bed up with the desired powder. You may use the powder funnel provided in the Dedicated Powder Tools. Press **DONE**.

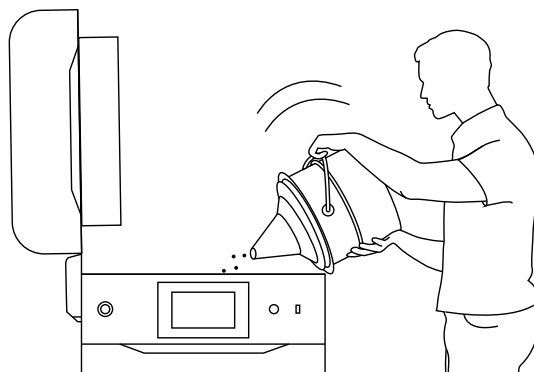

Fig. 2.4 Filling the print chamber with powder using a funnel.

**IMPORTANT!**

Add a little more powder than fits in the Feed Bed.

**IMPORTANT!**

The information which powder to use has been displayed on the printer screen as well as in the Sinterit Studio software end report.

6. Compress the powder using the powder trowel provided in the Dedicated Powder Tools. This will release any residual air accumulated in the Feed Bed. Press **DONE**.

2.4 Preparing the print chamber

1. Remove powder remaining under the guide bars. You may use the brushes and spatulas provided in the Dedicated Powder Tools. Press **DONE**.
2. Press **START LEVELING** to begin leveling the powder surface.

**IMPORTANT!**

During the powder leveling process you can scrape the excess powder from under the guides with a plastic spatula, for example from the Dedicated Powder Tools set.

**CAUTION!**

Risk of crushing hands! The moving recoater can cause hand injuries.

3. Press **STOP LEVELING** if the surface of the powder in the print chamber is smooth or wait until the recoater completes the process by itself. You can repeat the process by pressing **REPEAT LEVELING**. Press **DONE**.
4. Remove powder from the guide bars. Use a brush or a cotton cloth. Press **DONE**.
5. Apply silicone oil (available in the Dedicated Powder Tools) on the recoater guide bar. A few drops along the whole length is enough. Press **DONE**.
6. Delicately wipe the pyrometer window with a wipe soaked in 2% salicylic spirits (ethanol solution) or another ethanol - based cleaning solution. You may also use cleaning wipes provided in Dedicated Powder Tools.
7. Wipe the pyrometer window again with a dry cotton cloth, in order to remove any alcohol residue. Press **DONE**.
8. Make sure no miscellaneous items (i.e. spatulas) remain in the print chamber, then close the lid. Press **DONE**.

**CAUTION!**

Be careful not to crush your hands when closing the printer lid.

**IMPORTANT!**

If the printout requires it, connect the source of inert gas to the inlet nipple. Press the **CHECK PRESSURE** button to verify the inert gas control system.

2.5 Final steps before printing

1. Press the **RESET** button on the printer, in order to activate the security system.
2. Press **START PRINT**. Before printing, an automatic component check will be performed.
3. You can stop the process at any time, just press **ABORT PRINTING**.

**ATTENTION!**

If anything during the printer operation concerns you, press the **E-STOP** button and contact our after sales team: support@sinterit.com



3. Removing and cleaning the printout

1. When it becomes possible to remove the printout, the **REMOVE PRINTOUT** button will be displayed. Press **REMOVE PRINTOUT**.
2. The screen may display a message about the maintenance time of the components. For more information consult the full instruction manual, and our website: www.sinterit.com/support/. Press **GOT IT**. If the message hasn't appeared, it means that at present no components require any maintenance.
3. Press the **UNLOCK LID** button to release the electrolock and allow the print chamber to be opened



IMPORTANT!

After 10 seconds the lock will re-engage and it will no longer be possible to lift the lid. If you still want to open the printer lid, press the **UNLOCK LID** button again on the screen.

4. Push on the lid and pull it up using the handle (fig. 3.1).

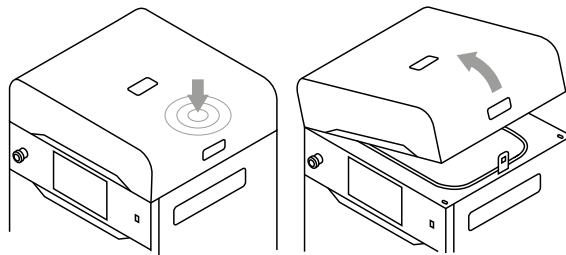

Fig. 3.1 Lifting the printer lid.

5. Make sure no miscellaneous items remain in the print chamber and press **POSITION BEDS**.
6. Place the folded IO BOX inside the print chamber. Make sure its elements are arranged like in the picture (fig. 3.2.)

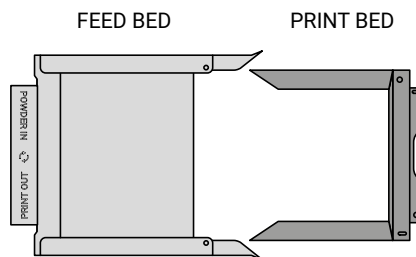

Fig. 3.2 The proper arrangement of the IO BOX, allowing the user to remove the finished printout.



ATTENTION!

While placing the IO BOX in the chamber, make sure you do not accidentally damage its components.

7. Unfold the IO BOX elements as much as possible. Inside the IO BOX you should see a covered Feed Bed and an uncovered Print Bed.
8. Press **REMOVE PRINTOUT** and wait until the content of the Print Bed (the cake) is ejected.
9. Close the IO BOX.
10. Carry the IO BOX and its contents onto the foldable tray from Dedicated Powder Tools **1** or on the PHS worktop **2** then press **DONE** on the screen.

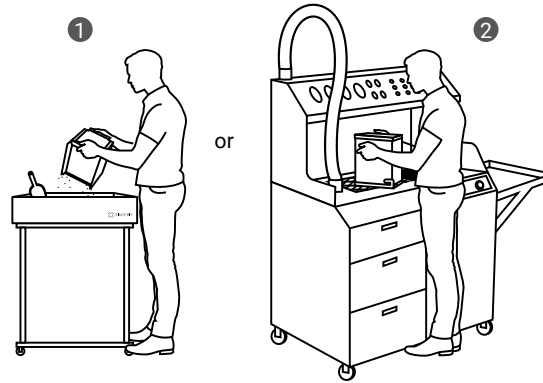

Fig. 3.3 Moving the IO BOX to the foldable tray ① or to the PHS worktop ② to clean the printout.

11. Clean the printout from unsintered powder. You may use the accessories provided in Dedicated Powder Tools.

4. Cleaning the printer



IMPORTANT!

The SLS powders are hygroscopic (draw moisture out from the air). The print chamber and the overflow container are not 100% airtight. Leaving the powder inside of the printer may cause it to become wet and lose its intended properties.



IMPORTANT!

If you do not want to clean the printer immediately after pulling the printout, you can do this later. On the main menu screen, press **MAINTENANCE** ↻ button and then **CLEAN THE PRINTER** button.

1. Press **CLEAN THE PRINTER** to start cleaning the printer.
2. Make sure no tools remain in the print chamber. Press **POSITION BEDS** to begin the positioning process of the Beds.
3. Collect the remaining powder in the print chamber with the PHS or ATEX Vacuum Cleaner suction hose. Press **DONE**.



DANGER!

The vacuum cleaner used to collect the powder must be suitable for handling combustible dust. Sinterit recommends the ATEX Vacuum Cleaner available in the offer.

4. Press the arrow buttons to move the recoater and collect the remaining powder underneath. Press **DONE**.
5. Press **UNLOCK DOOR**, to open the printer door.
6. Press **UNLOCK OVERFLOW** and slide out the overflow container (Fig 4.1).



IMPORTANT!

After 10 seconds the electrolock will activate and it will no longer be possible to slide out the overflow container. If you still want to slide out the overflow container, press the **UNLOCK OVERFLOW** button again on the printer screen.

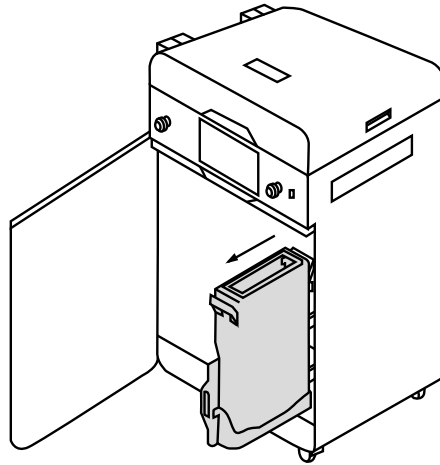

Fig. 4.1 Sliding out the overflow container.

7. Take the overflow container from its drawer and transfer its content into a metal container or onto the PHS worktop.
8. Put the overflow container back in its drawer.



IMPORTANT!

Make sure the overflow container is oriented correctly once you put it back. Pay attention to the markings on the container.

9. Press the **UNLOCK OVERFLOW** button to release the lock and slide the drawer back into the printer.



ATTENTION!

Attempting to slide the overflow container back into the printer without unlocking the security system may damage the drawers mechanisms.

10. Close the printer door and press **DONE**.
11. If you want to know how much fresh powder you need to add to the used powder press **SHOW REFRESH INFO**. If you wish to instead do that another time, press **SKIP**.

5. Technical support

In case of any questions or issues, please don't hesitate to contact our After sales team:

- e-mail: support@sinterit.com
- phone: +48 570 702 886

The full list of resellers and technical support in select countries can be found at www.sinterit.com/contact.

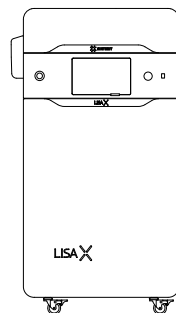
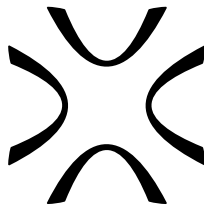

SINTERIT Sp. z o.o.
ul. Nad Drwina 10 bud. B3, 30-741 Krakow, Poland
www.sinterit.com
Contact: +48 570 967 854